

Introduction to the Building Standard Law

- Building Regulation in Japan -

(Ver. July 2013)

Written by Mr. HASEGAWA Tomohiro
(The Ministry of Land, Infrastructure, Transport and Tourism, Japan)

Published by the Building Center of Japan

< Copyright and others >

The copyright of this text is held by the Building Center of Japan (BCJ).

This text is based on the Building Standard Law and related regulations. It is intended to be used solely as a reference to facilitate in the understanding of the Law and related regulations. BCJ will not be responsible for any consequences resulting from the use of the information in this text.

The Building Center of Japan (BCJ)

<http://www.bcj.or.jp>

1-9, Kanda-Nishikicho, Chiyoda-ku, Tokyo, 101-8986, Japan

< 著作権その他の注意事項 >

このテキストの著作権は財団法人日本建築センター（BCJ）に帰属します。

このテキストは建築基準法及びその関係法令に関するものですが、それらの理解を助けるための参考資料として使用されることを意図したものであり、BCJはこのテキストの利用に伴って発生した問題について一切の責任を負いません。

一般財団法人 日本建築センター

<http://www.bcj.or.jp>

〒101-8986 東京都千代田区神田錦町1-9

Abbreviation

The BSL	The Building Standard Law
MLIT	The Ministry of Land, Infrastructure, Transport and Tourism
The Minister	The Minister of Land, Infrastructure, Transport and Tourism

Organizations related to the BSL

Name	Comments regarding responsibilities
The Minister	3-2
Designated Administrative Agency	3-3
Designated Confirmation and Inspection Body	3-4 (2)
Designated Structural Calculation Review Body	3-4 (4)
Designated Performance Evaluation Body	4-1 (3)
Designated Approval Body	4-4

Contents

Chapter 1	Background
Chapter 2	Laws related to the Building Regulations
Chapter 3	Building Regulatory System
Chapter 4	Composition of the Building Codes
Chapter 5	Building Codes for Structural Safety
Chapter 6	Building Codes for Fire Safety
Chapter 7	Building Codes for Other Fields
Chapter 8	Zoning Codes
Chapter 9	Seismic Retrofitting
	Annexes

Contents

Chapter 1 Background

1-1 Building Construction in Japan

1-2 Conflagrations

1-3 Earthquakes

1-4 Fire incidents

1-5 Other factors

1-1 Building Construction in Japan

(1) Residential buildings

- (a) In case of detached houses, share of wooden houses is around 90 %.
- (b) In case of apartments, share of wooden apartments is around 30 %.
- (c) It was prohibited to construct wooden apartments with three or more stories for long time in Japan. Under the current codes, it is possible to construct them with required counter measures against fire.

New Housing Starts (FY 2009: April 2009 – March 2010)

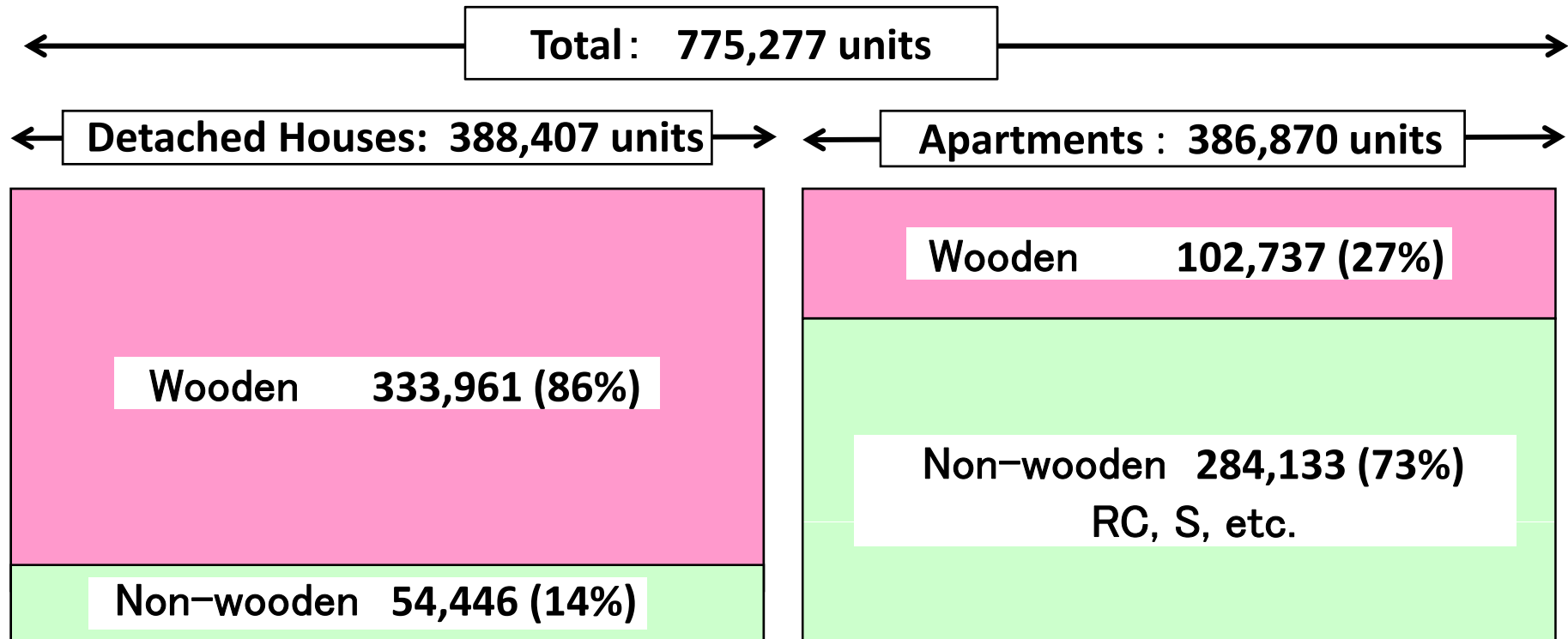

(2) Buildings other than residential buildings

(a) Wooden structure was the dominant type of structure until the end of 19th century.

Before the introduction of **the brick structure in the 1860s**, and the introduction of **the steel structure and reinforced concrete structure in 1900-1920**, the wooden structure was the dominant type of structure, including structure for public use, temples, shrines, and commercial use. Some of them still remain in the country.

Todaiji-temple,
wooden building
with height of 46.8 m,
1709



Himeji-castle,
wooden building
with height of 31.5 m
from the top
of the stone wall,
1608



(b) From the end of 19th century, construction methods other than wooden construction method was promoted for large buildings.

Construction methods other than wooden construction method was promoted for large buildings, because wooden buildings were considered vulnerable to fires and inferior in terms of durability.

(3) Reevaluation of Wooden Buildings

In the 1980s, Japanese people reevaluated wooden buildings, and engineering and administrative measures made it possible to construct large wooden buildings again.

(4) High-rise Buildings

(a) It was prohibited to construct buildings with height of more than 31 m for long time, because Japan is earthquake-prone country.

(b) In 1968, The first super high-rise building in Japan was constructed in 1968, of which height was 156 m, owing to the progress of building technology.

(a) There are around 2,500 super High-rise buildings with height of more than 60 m.

Kasumigaseki-building

Steel structure with height of 156 m
36 floors on the ground, 1968



Total Floor Areas of Annual Building Starts in Each Type of Construction in Japan (unit: 1,000 m²)

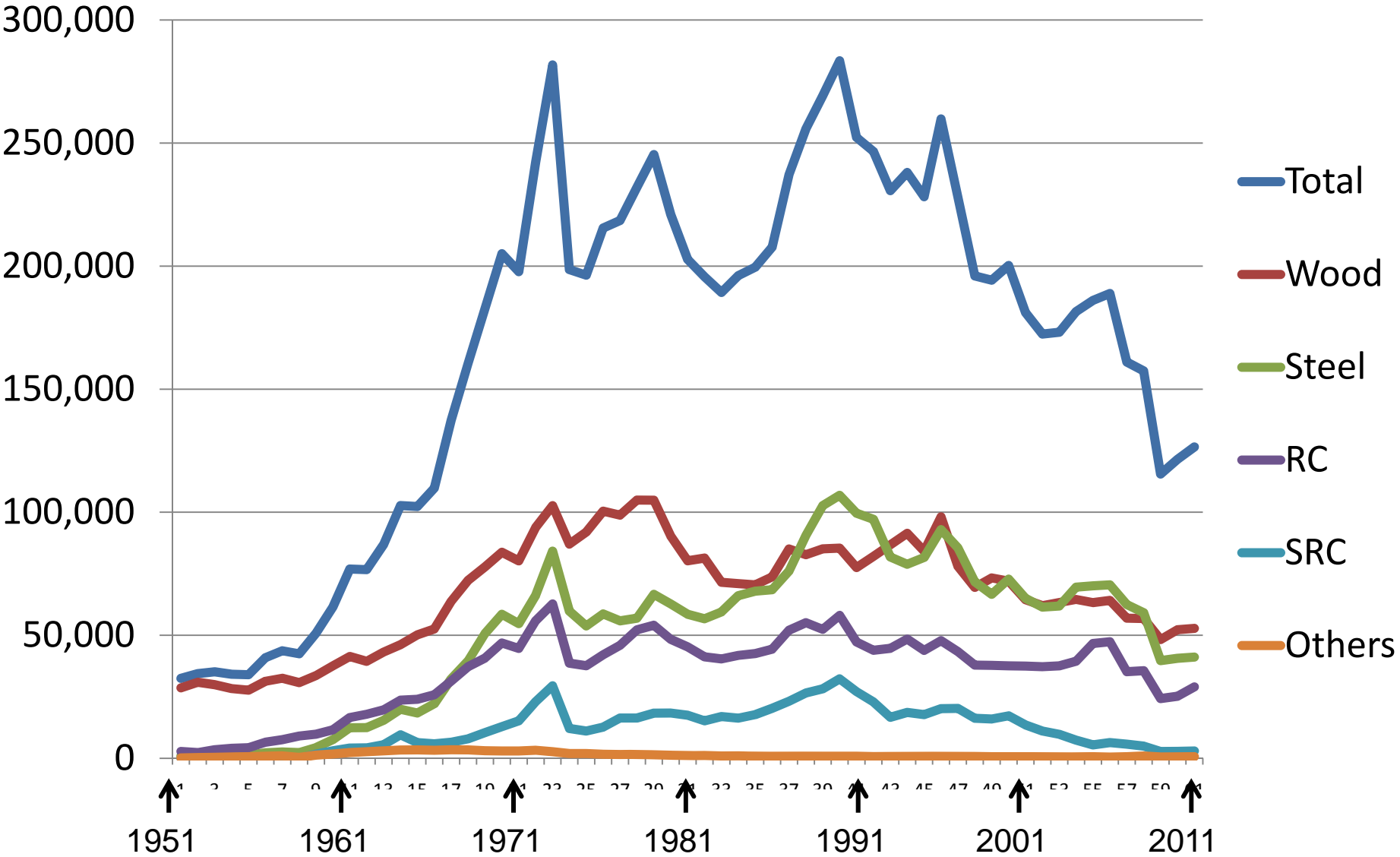

1-2 Conflagrations

The traditional Japanese building method is the wooden structure. Even now, most newly-built detached houses are wooden structures. On the other hand, Japan has a characteristic climate of dry air in winter, seasonal strong winds and foehn phenomena that arises in certain areas because of the mountainous land. Densely-built wooden buildings and the characteristics of climate produce a very high threat of fires – both small and large.

Therefore, it has been one of the main concerns in building control to prevent conflagrations by means of covering roofs and exterior walls with noncombustible materials, especially in central urban areas. Such restrictions have been in effect in Japan for around 350 years.



**Wooden
built-up area
in Japan**



1-3 Earthquakes

Japan is located on the boundaries of four Plates.

Around Japan

World Map of Plate Boundary

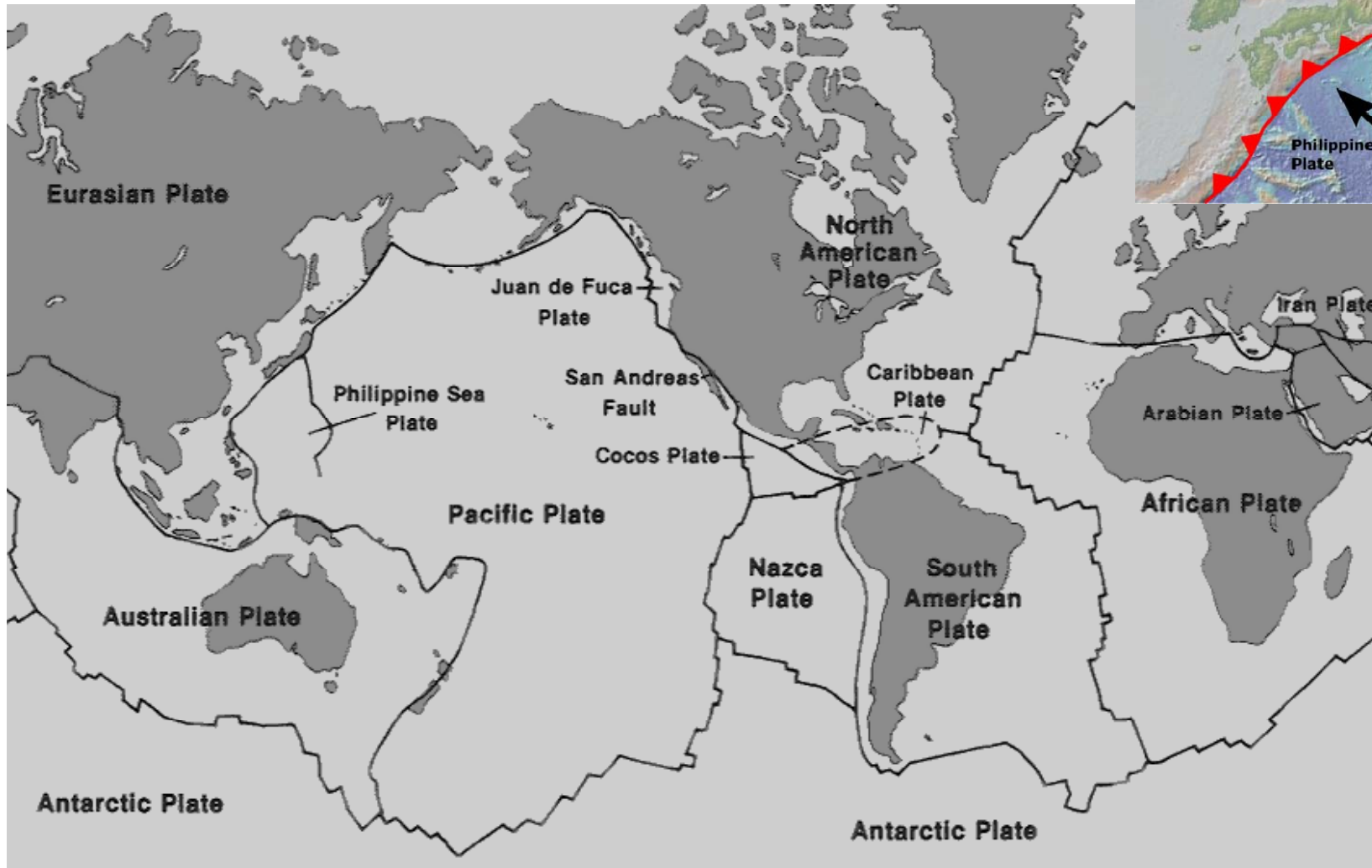
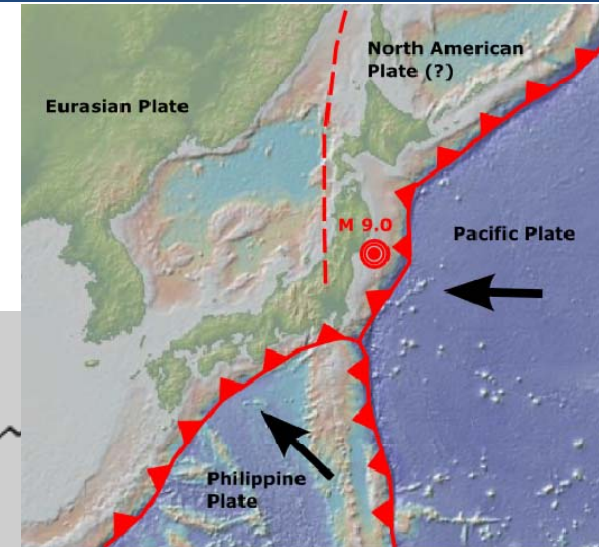

(1) Great Kanto Earthquake (1923)

It hit Tokyo and surrounding regions and caused simultaneous outbreaks of fire in many places, with approximately **450,000 buildings being destroyed by fire**, and **some 143,000 persons dead or missing**.



Devastated area in Tokyo

One of the main concerns in building control has been to construct buildings that can withstand earthquakes. The Japanese Building Code has required **structural calculation in considering seismic force since 1924 (The next year of the Great Kanto Earthquake)**. This was the first such requirement in the world.

Specific structural provisions were also strengthened, for instance;

- Wooden braces for wooden buildings (Wooden braces were required only for wooden buildings of 3 or more stories before the amendment.)
- Tie hoops for RC buildings.

(2) Great Hanshin-Awaji Earthquake (1995)

It hit Kobe city and surrounding regions and 104,906 buildings collapsed, and 6,148 buildings were severely damaged, causing 6,433 deaths. It is estimated that 80 % of the deaths were due to falling buildings or furniture.

Most of the collapsed buildings were those which were constructed before 1981, when the new seismic building regulations were enforced. Therefore, seismic reinforcement of old buildings became an urgent issue in Japan.



(3) Great East Japan Earthquake (2011)

It hit the Pacific coast of Tohoku of Japan. The seismic damage to buildings was not so much in considering the scale of the earthquake. Extremely destructive tsunami waves attacked the coast area and of Tohoku of Japan and caused around 20,000 people of death or missing.

Following Issues are focused in the field of buildings.

- Restriction of buildings in tsunami hazardous area
- Placement of tsunami evacuation building (buildings to help people vertically evacuate from tsunami)

Tsunami detecting system and warning system will be improved.



In case where the flood water depth was more than 2 m, tsunami-induced damage was much severer than the case where the depth was less than 2 m.

Tsunami Evacuation Building

As of March 2010, 1,790 tsunami evacuation buildings were designated in the whole country, according to the design guideline for tsunami evacuation buildings, which provide necessary evacuation height, accommodation capacity, structural requirements, etc. responding to the particular conditions, such as expected flood water depth and location..

Learning from the lessons of the Great East Japan Earthquake, Structural Design Method from the Viewpoint of Structural Safety against Tsunami was compiled.

The structural design method will be utilized for:

- Designation of tsunami evacuation building, and
- Structural requirements to the buildings in the tsunami hazardous areas.

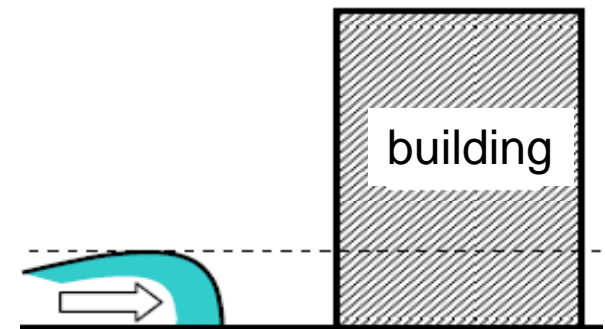

Image of tsunami evacuation building



Tsunami evacuation building that withstood tsunami
- 200m from the coast
- Flood water depth was more than 13m.

《Major earthquakes》

1923 Great Kanto eq.

1964 Niigata eq.

1968 Tokachi Off-shore eq.

1978 Miyagi Off-shore eq.

1995 Great Hanshin-Awaji eq.

2004 Niigata-Chuetsu eq.

2005 West Off Fukuoka eq.

2007 Off Niigata-Chuetsu eq.

2007 Noto Peninsula eq.

2008 Iwate-Miyagi Inland eq.

2008 Iwate North Coast eq.

2011 Great East Japan eq.

Trends in development of earthquake-resistance measures

1924 **Structural calculation regulation in considering seismic force (First such requirement in the world)**

1950 **Enactment of the Building Standard Law (BSL)**

1971 **Amendment of the BSL**

- Strengthening of RC standards

1981 **Amendment of the BSL (New Seismic Codes)**

- Not damaged by medium-scale earthquakes
- Not collapsed by large-scale earthquakes

1995 **Enactment of the Act on Promotion of Seismic Retrofitting of Buildings**

- Approval of seismic retrofitting plans

1998 **Amendment of the BSL**

- Building confirmation by private sector, introduction of interim inspection, performance-based standards

2006 **Amendment of the Act on Promotion of Seismic Retrofitting of Buildings**

- Making a plan for promoting seismic retrofitting by local government

Many buildings built before 1981 do not comply with the current seismic standard.

1-4 Fire incidents

After large buildings became popular, there were sometimes conflagrations in these buildings. Therefore, Japanese building codes were revised to strengthen fire safety of such buildings.

(1) Fire codes concerning **necessary number of stairs, interior finishing materials, etc. was strengthened in 1973**, in considering such fire incidents on the right.



Sen-nichi
department
store (1972)
118 deaths



Taiyo department store
(1973) 100 deaths

(2) Fire codes concerning **automatic sprinkler systems, etc. was strengthened in 1980s**, in considering such fire incidents below.



Hotel New Japan
(1982) 33 deaths

Kawaji Prince hotel
(1980) 45 deaths



1-5 Other factors

(1) Typhoon and snow

Japan is also situated in the path of typhoons. Buildings face the threat of strong winds from typhoons, and buildings near mountains are threatened by landslides caused by heavy rainfall of typhoons. Therefore, buildings must be able to resist the strong winds from typhoons. The possibility of landslides must be considered when planning for construction near mountains. Additionally, in the northern part of Japan, the weight of accumulated snow on roofs must be considered.

(2) Health

In order to secure the health of occupants and public health in general, buildings must have an adequate sanitary system, to prevent sick house issues, and so on.

(3) City planning

From the viewpoint of city planning, buildings are required to be designed within a certain height, to meet land-use planning, and so on. In many countries, such requirements (zoning codes) are provided by the system separated from the building codes system. Relationship between both system is mentioned later.

Contents

Chapter 2 Laws related to the Building Regulations

1-1 Laws related to the building regulations

1-2 Building Standard Law

1-3 Fire Service Law

1-4 Barrier-free Law

1-5 *Kenchikushi* Law

1-1 Laws related to the building regulations

The BSL is the primary law concerning building codes. Other laws concerning building codes and related fields are shown in the table below.

Building codes items and related fields		Restrictive laws (Requirements are mandatory.)	Promotional laws
Fire safety	Fire extinguishing equipment, etc.	Fire Service Law	
	Fire- resistance, evacuation, etc.	Building Standard Law	
Structural safety			Seismic Retrofitting Law
Hygienic safety			Building Management Law
Accessibility		Barrier-free Law	
Energy saving			Energy Saving Law

(1) Purpose of the BSL

The BSL was enacted in 1950, The purpose is to safeguard the life, health, and property of people by providing minimum standards concerning the site, construction, equipment, and use of buildings, and thereby to contribute to the furtherance of the public welfare.

(2) For all buildings

The BSL is a law that applies to all buildings throughout Japan. However, the standards that it provides for are not uniform throughout the country because additional standards are determined in accordance with regional conditions. For example, the method of structural calculation and fire safety must take into account factors such as snow accumulation, earthquake activity and other conditions of each area.

(3) Restrictive law

The BSL is enforced through administrative procedure, and all buildings must conform to requirements determined by the BSL and the documents under the BSL. For example:

- (a) It is required to have both a building confirmation and inspection by a building official or a fair and impartial private sector organization (a designated checking and inspection organization) to determine whether the building is in compliance with the BSL and other laws concerning buildings.
- (b) Additionally, it prescribes that the Designated Administrative Agency (see Chapter 3) has the power to call a halt to the construction of a building or to order the demolition or prohibition of the use of buildings that are judged to be in violation of the BSL.

(4) Covering the main parts of the building codes

Technical requirements based on the BSL cover the fields below:

- (a) Structural safety
- (b) Fire safety
- (c) Hygienic safety

They are the main parts of the building codes, but it is not a complete list. For example, the BSL does not cover technical requirements for fire extinguishing equipment. They are covered by the Fire Service Law.

(5) Covering the fields of zoning codes

Technical requirements based on the BSL cover not only the main parts of the building codes, but also basic requirements for zoning codes. The BSL and documents under the BSL cover the basic requirements of zoning codes, which are:

- (a) mandatory and apply to every building in the City Planning Area and Quasi City-Planning Area designated by city planning, and
- (b) aimed to secure buildings to fulfill city planning, and

which stipulate:

- building use regulations;
- height regulations from the viewpoint of landscape/cityscape; and
- others.

(6) From construction of a building until its destruction or demolition

The BSL is applied continuously from the time of construction of a building to the time of its destruction or demolition. It therefore provides regulations that stipulate maintenance and periodic inspections of buildings.

1-3 Fire Service Law

The purpose of the Fire Service Law is:

- (a) to prevent, detect and extinguish fires, and to protect people's lives, health, and property from fires; and
- (b) to minimize damage caused by fires, earthquakes, and other disasters.

The Law requires that certain buildings be equipped with fire extinguishing equipment, such as automatic sprinkler systems.

Requirements provided by the Fire Service Law are checked by fire departments of local governments in the process of building administrations.

1-4 Barrier-free Law

The Barrier-free Law has some provisions relating to the building regulations as below.

(a) Requirements of the standard

When undertaking certain types of construction work of a special specified building^{*1} with a total floor area of 2,000 m² or more, accessibility and mobility standards^{*3} must be complied with. **These requirements are checked in the process of building administrations.**

(b) Promotion of conformance to the standard

Building owners undertaking certain types of construction work of a specified building^{*2} must make efforts to comply with accessibility and mobility standards^{*3}.

- *1. Special specified buildings are any specified buildings^{*2} used by many, and unspecified persons, or those used primarily by the elderly or physically disabled. Examples are hospitals, theaters, assembly halls, department stores, hotels, and homes for the aged.
- *2. Specified buildings are buildings used by many people, such as schools, hospitals, theaters, assembly halls, department stores, hotels, offices, apartments, and factories.
- *3. Examples of accessibility and mobility standards are:
 - the securing of a hallway wide enough to allow for a wheelchair user and a passer by; and
 - installation of at least one commode designed for wheelchair users.

Accessibility and Mobility Standards of Buildings

In Japan, when someone intends to construct buildings, such as hospitals, theaters, assembly halls, department stores, hotels, and homes for the aged, with a total floor area of 2,000 m² or more, the buildings must be designed in accordance with the accessibility and mobility standards.

Figure below shows the points of the standards. Number, width, length, etc. of each equipment are stipulated in the standards.

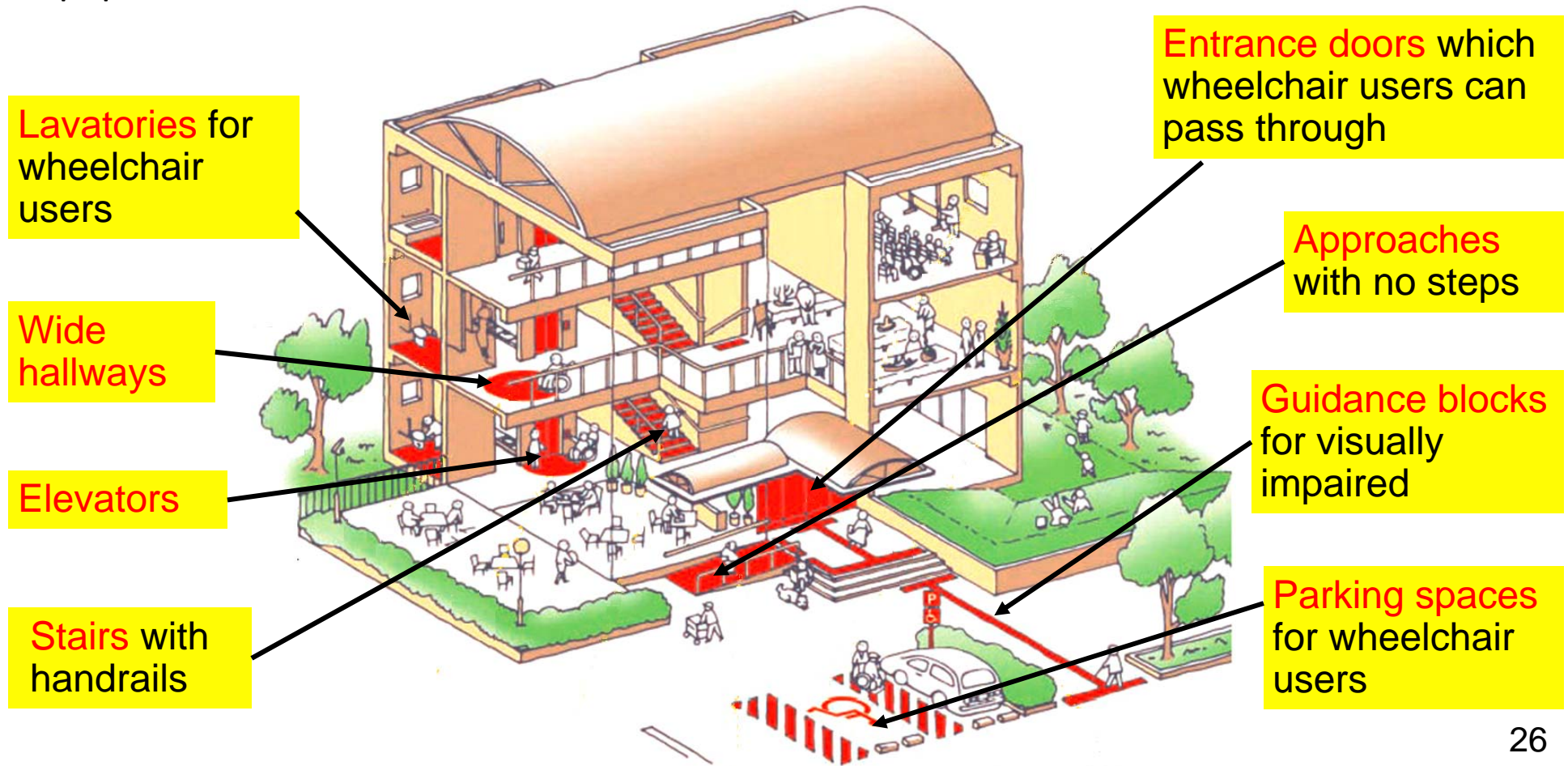

1-5 *Kenchikushi* Law

The *Kenchikushi* system is a national qualification system under the *Kenchikushi* Law.

Kenchikushi are licensed:

- to **design** buildings (see (1)); and
- to **conduct construction administration** (see (2)).

The *Kenchikushi* system has a linkage with building regulations to ensure the safety of the buildings.

(1) To design buildings

To **design** buildings includes both;

- the role of architect, such as making architectural drawings and specifications, and
- the role of building engineer, such as performing structural calculations, and MEP (mechanical, electrical, and plumbing) system design.

Thus, *Kenchikushi* have the dual role of architect and building engineer, while many countries have separate licensing systems for architects and building engineers.

(2) To conduct construction administration

Check of construction works is done by both an owner's party and a builder's party in Japan. Their responsibilities are shown as below.

- (a) A builder's superintendent is an employee of the builder and is responsible for overseeing building construction on behalf of the builder to ensure good quality.
- (b) A person who **conducts construction administration** is responsible for examining building construction on behalf of the building owner, to determine whether or not the said construction follows the drawings/specifications made by a *Kenchikushi*.

In Japan, builders are allowed to engage in construction of buildings that they themselves have designed. Actually, many buildings (especially small buildings, such as detached houses) are constructed by the same company that designed the buildings. In almost all of these cases, Person who conduct construction administration are assigned from these companies.

(3) License and Scope of Activity by Type of *Kenchikushi*

The qualifications of *Kenchikushi* are classified into three types:

- (a) *1st-class Kenchikushi*;
- (b) *2nd-class Kenchikushi*; and
- (c) *Mokuzo (wooden structures) Kenchikushi*.

In principle, a person who:

- has necessary educational background and job experience of architecture; and
- passed the official examination;

can be registered to:

- the Minister for *1st-class Kenchikushi* ; and
- *Prefectural Governors* for *2nd-class Kenchikushi* and *Mokuzo Kenchikushi*.

The *Kenchikushi* Law stipulates the use, structure, height, etc. of buildings, that only *Kenchikushi* may **design** and **conducts construction administration** as shown in the next page.

Scope of Activity by Type of *Kenchikushi*

Height and structure Total floor area (S: m ²)		height of building ≤ 13 m and Height of eave ≤ 9 m					Height of building > 13 m, or Height of eave > 9 m
		wooden			Non-wooden		
		1 story	2 story	3 story	Up to 2 stories	3 stories or more	
$S \leq 30$		Anyone can engage in this.			Anyone		
$30 < S \leq 100$							
$100 < S \leq 300$		1st, 2nd, or <i>Mokuzo</i> may engage in this.					
$300 < S \leq 500$		Only 1st-class or 2nd-class may engage in this.					
$500 < S \leq 1,000$	General-purpose buildings						
	Special-purpose buildings						
$1,000 < S$	General-purpose buildings				Only 1st-class may engage in this.		
	Special-purpose buildings						1st, 2nd

Note: *Special-purpose buildings* refer to schools, hospitals, theaters, cinemas, grandstands, public halls, assembly halls with auditoriums, and department stores.

(4) *Structural Design 1st-class Kenchikushi and MEP Design 1st-class Kenchikushi*

In principle, a person who:

- engaged in the services of structural design (MEP design) for five years or more as a *1st-class Kenchikushi*; and
- completed the designated training program;

may apply for issuance of a *Structural Design 1st-class Kenchikushi (MEP Design 1st-class Kenchikushi)*.

(a) Structural Design 1st-class Kenchikushi

In the case of buildings over a certain size (*1), either of the following is required:

- (i) A *Structural Design 1st-class Kenchikushi* designs the building, and also examines that the building meets the relevant codes and standards for building structures.
- (ii) A *1st-class Kenchikushi* designs the building, and a *Structural Design 1st-class Kenchikushi* examines that the building design meets the relevant codes and standards for building structures.

(*1) - Steel buildings with 4 or more stories (excluding basement);

- RC or SRC buildings of 20m or more in height;
- Wooden buildings with building height of more than 13 m or eave height of more than 9 m; and
- Buildings stipulated by the Cabinet Order.

(b) MEP Design 1st-class Kenchikushi

In the case of buildings larger than 5,000 m² with more than 3 stories, either of the following is required:

- (i) A *MEP Design 1st-class Kenchikushi* designs the building, and also examines that the building meets the relevant codes and standards for building equipment.
- (ii) A *1st-class Kenchikushi* designs the building, and a *MEP Design 1st-class Kenchikushi* examines that the building design meets the relevant codes and standards for building equipment.

Contents

Chapter 3 Building Regulatory System

3-1 Legislation

3-2 Administration by the Central Government

3-3 Administration by local governments
(Designated Administrative Agency)

3-4 Regulatory procedures

3-5 Measures against buildings in violation

3-6 Declaration of dissatisfaction

3-1 Legislation

(1) Local governments in Japan

There are **two levels of local governments** in Japan; prefectures and basic local governments.

(a) **Japan consists of 47 prefectures.**

(b) **Each prefecture consists of basic local governments, such as cities, towns and villages.** Total number of basic local governments is 1,742 (as of April 2012), including:

- 787 cities;
- 748 towns;
- 184 villages; and
- 23 wards in Tokyo.

Take Tokyo for example of a prefecture: there are 23 wards, 26 cities, 5 towns, and 8 villages in its area.

A president of each local government is directory elected by its local residents, who is called a Governor or a Mayer.

All members of each parliament of local governments are directory elected by its local residents.

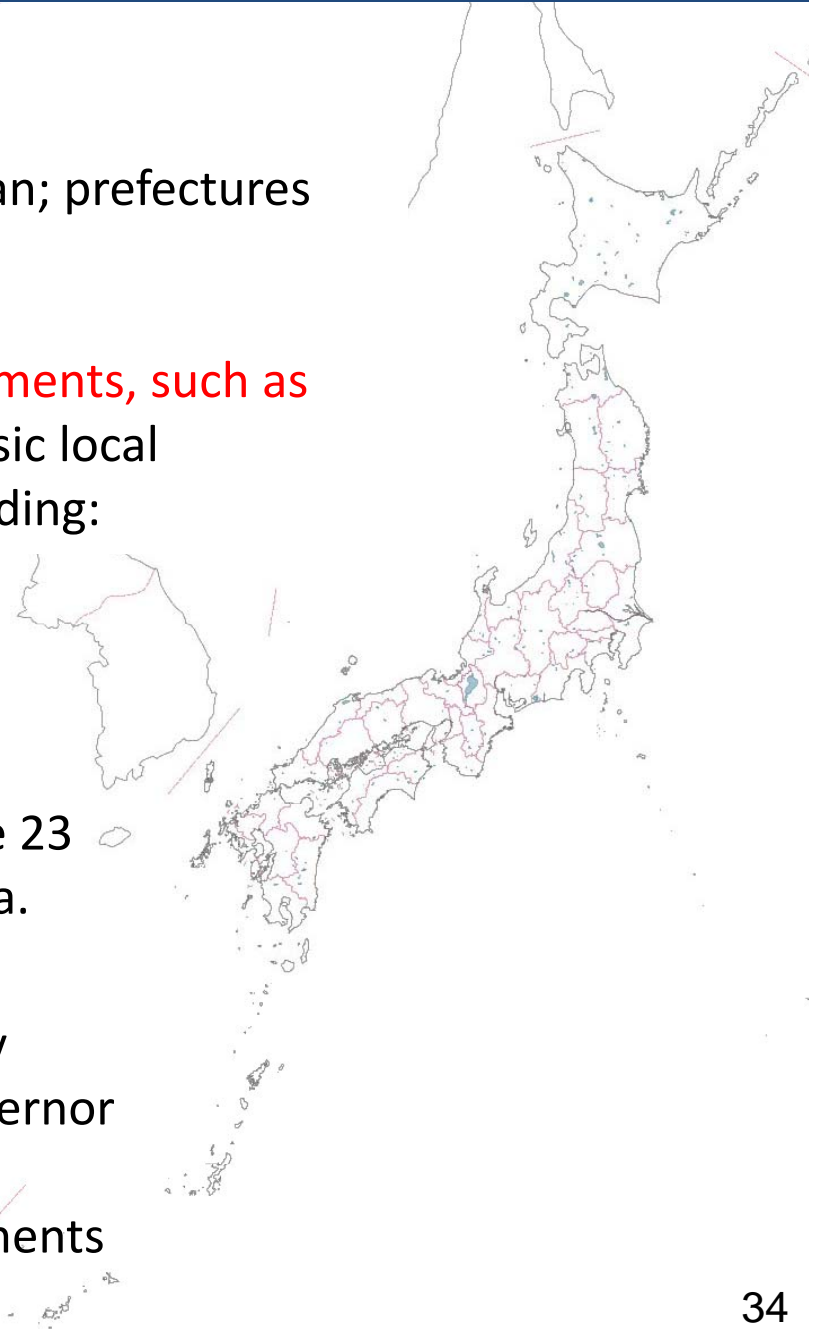

(2) Legislation by the Central Government

The Central Government legislates for building regulations based on the BSL in Japan. **The building regulatory systems and building codes (technical requirements) are basically common all over the country. And its administration is carried out by local governments as stipulated by the BSL.**

(3) Legislation by local governments

On the other hand, regional conditions, such as climate and earthquake risk, are different among regions. Therefore, local governments are entrusted to determine some items, such as:

- (a) Figures used for structural calculation, such as snow accumulation, wind pressure and seismic force;
- (b) Specific zones where restrictions on external finishes are placed in order to prevent buildings from catching fire;
- (c) Specific process of construction work, for which interim inspections are needed.

And local governments may , within specific limits and within the scope of not disrupting the safety of buildings, set more severe or more relaxed regulations than the standard applied throughout the country.

(4) Legislation documents

Provisions are provided in the documents in the table below.

Authorities to issue		Documents	Main contents
Central Government	National assembly	The BSL (the Building Standard Law)	<ul style="list-style-type: none"> - Procedures, such as confirmation, permission, certification system - Penalties - Technical requirements (outline)
	Cabinet	<i>The Enforcement Order</i>	<ul style="list-style-type: none"> - Technical requirements
	<i>MLIT</i>	<i>The Enforcement Regulation of the Ministry</i>	<ul style="list-style-type: none"> - Procedures (Details, such as application forms)
	<i>MLIT</i>	<i>Notifications of the Ministry</i>	<ul style="list-style-type: none"> - Technical requirements (Details)
Local governments	Local assembly	Bye-laws	<ul style="list-style-type: none"> - Additional technical requirements in response to their local conditions.
	Governor or Mayor	Enforcement Regulations	<ul style="list-style-type: none"> - Procedures (Details) - Technical information, such as snow accumulation, earthquake risk, etc.

(5) Building regulatory systems in various countries

Country	Japan	UK (England & Wales)	Australia	Canada	USA
Legislation of building regulatory systems system of permission, inspection, etc.	Central Government Supplementary provisions by local governments		States and local jurisdictions		
Issuance of building codes technical requirements	Central Government Supplementary or additional provisions by local governments		States and local jurisdictions Each country has model building code.		
Administration issuance of building permission, etc.	Local jurisdictions and Designated/approved/registered private bodies		States or local jurisdictions		
Judgment of alternative solution Alternative solution of materials, construction methods, and building design	Minister Evaluation by one of the Evaluation Bodies is required prior to Ministerial approval.		Local jurisdictions and Private bodies	States or local jurisdictions Assessment, such as evidence and evaluation reports, can be used for the judgment.	

3-2 Administration by the Central Government (The Minister)

Based on the BSL, the power and commission of the Minister includes:

- (a) submissions of proposals to the Japanese Diet for amendments to the BSL;
- (b) submissions of proposals to the Cabinet for amendments to the Enforcement Order;
- (c) issuance of (i) *The Enforcement Regulation of MLIT*, (ii) *The Ministerial Order Concerning Designated Qualifying Examination Body and Others*, and (iii) *MLIT Notifications*;
- (d) conducting qualifying examinations for *Building Regulation Conformity Inspectors*, and the registration of qualified people;
- (e) Designating (i) *Confirmation and Inspection Bodies*, (ii) *Performance Evaluation Bodies*, (iii) *Approval Bodies*, and (iv) Others.
(*Confirmation and Inspection Bodies* whose scope of work is limited within a specific prefecture are designated by the prefectural governors.)
- (f) giving the necessary orders to the designated bodies mentioned in (e);
- (g) approving building materials, building components and building designs that meet performance criteria, but do not satisfy sample specification, prescriptive requirements nor *Ordinary Verification Methods*; and
- (h) others.

3-3 Administration by local governments (Designated Administrative Agency)

As of Apr. 2012,

- (a) **227 basic local governments** of 1,742 basic local governments, including major cities, conduct building control administration **for all buildings regardless of their sizes**.
- (b) **174 basic local governments** of 1,742 basic local governments, including 23 wards in Tokyo, conduct building control administration **for limited sized buildings**.
- (c) **47 prefectures** conduct building control administration **for buildings, which are not administrated by (a) or (b)**.

The responsible agency of each area is as shown in the next page.

448 local governments ((a)+(b)+(c)) are called a ***Designated Administrative Agency***.

Building officials under the *Designated Administrative Agencies* are in charge of:

- (i) building confirmation; and
- (ii) on-site inspections.

Designated Administrative Agencies are in charge of:

- (iii) receipt of reports of periodic inspections; and
- (iv) measures against violations.

Designated Administrative Agency in response to the area and the building

Area \ Building	(1) Large buildings (Buildings other than (2))	(2) Small buildings, such as detached houses of not more than two stories.
(a) Areas of 227 basic local governments They are major cities in Japan, and their mayors are <i>Designated Administrative Agencies</i> . Most of them have a population of more than 100,000.	Basic local governments are in charge of building control.	
(b) Areas of 174 basic local governments Most of them are small cities, and their mayors are <i>Designated Administrative Agencies</i> . They are in charge of building control of small buildings only.	Prefectural governments are in charge of building control.	Basic local governments are in charge of building control.
(c) Other areas Area of around 1,300 basic local governments in Japan. Most towns and villages are included.	Prefectural governments are in charge of building control.	

Number of local governments is as of April 2011. 23 wards in Tokyo are categorized in (b), however they are responsible for larger buildings than those stated in this table.

3-4 Regulatory procedures

Each procedure is mentioned in the part where each number in bracket shows.

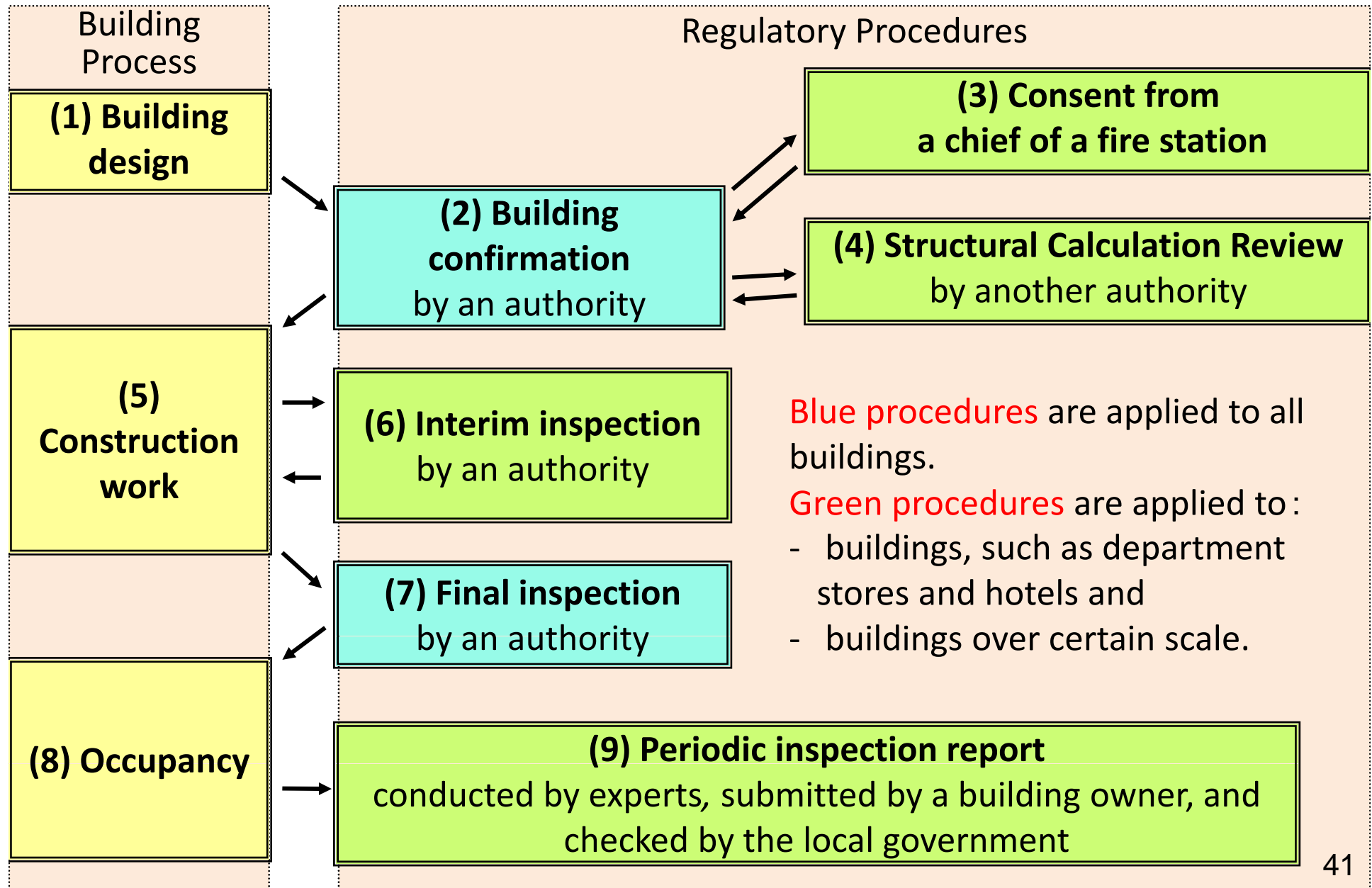

(1) Building Design

The *Kenchikushi* Law stipulates that only *Kenchikushi* may perform building design, except for small buildings. The BSL prohibits implementing building construction if its drawings are made in violation of the *Kenchikushi* Law.

(2) Building Confirmation

Generally, in cases where a certain building is to be constructed, extended, rebuilt or relocated, a building owner must apply for and receive building confirmation from:

- a **building official** under the *Designated Administrative Agency* in charge of building control in the area; or
- **one of the *Designated Confirmation and Inspection Bodies*** (see the next page) to determine whether the plan of the building conform to technical regulations based on the laws (not limited to the BSL) .

Designated Confirmation and Inspection Body

Designated Confirmation and Inspection Bodies conduct:

- (i) building confirmation; and
- (ii) on-site inspection;

both of these are conducted as a fair and impartial private sector organization. The designation is done by the Minister or prefectural governors. Their works are performed by conformity inspectors who have passed the qualifying examination for *Qualified Building Regulation Conformity Inspectors*. **This system was introduced in 1999.** On the other hand, building officials under *Designated Administrative Agencies* are, as mentioned in **3-3**, also in charge of (i) and (ii), above. The effect of the certificate issued by a *Designated Confirmation and Inspection Body* is the same as that of a building official under the *Designated Administrative Agency*. Their achievement is as shown below.

Designated Administrative Agency & Designated Confirmation and Inspection Body

	Number of authorities (Apr. 2012)	Number of building confirmations (2011 Japanese fiscal year)	
<i>Designated Administrative Agencies</i>	448	96,984 (18 %)	
<i>Designated Confirmation and Inspection Bodies</i>	124	448,363 (82 %)	
Total	572	545,347	43

Number of Building Confirmations in Japan

X 10,000 cases

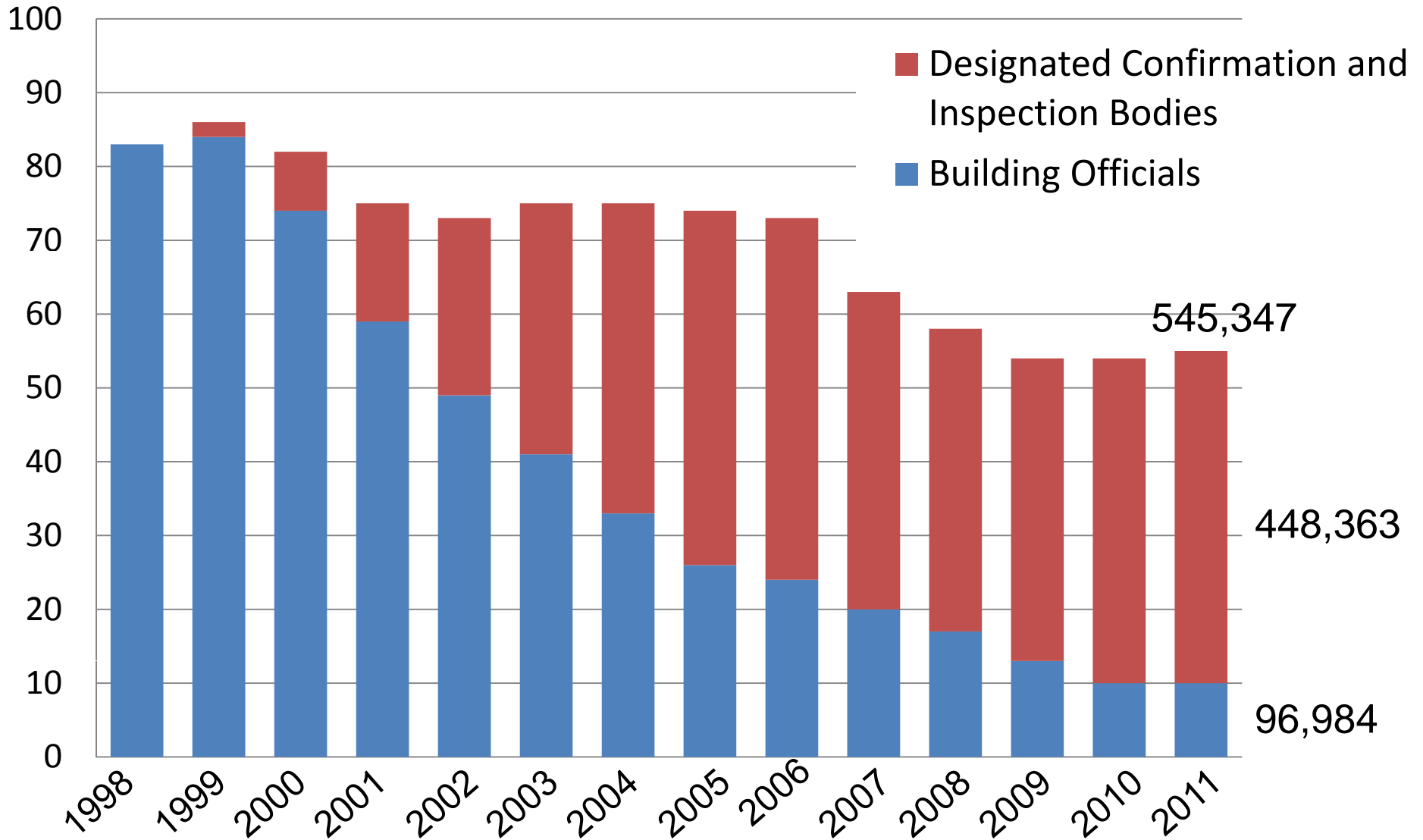

Fiscal Year (April to March of the next year)

(3) Consent from a chief of a fire station

Before giving building confirmation, a building official and a *Designated Confirmation and Inspection Body* must obtain consent from:

- (a) the chief of the local fire station; or
- (b) the fire inspector. (If it is a city, town or village without a fire department, the head).

However, this does not apply in such case that the building requiring confirmation is a detached house, located outside of *Fire Protection Zones* and *Quasi Fire-Protection Zones*.

(4) Structural Calculation Review

- (a) Skyscrapers with more than 60 m in height, and buildings using advanced structural calculation methods, are required that their safety be confirmed by a *Designated Performance Evaluation Body (*1)* and approved by the Minister.

(*1) Designated Performance Evaluation Body

A *Designated Performance Evaluation Body* conducts an evaluation to determine whether or not the solution meets performance requirements (performance criteria) upon request by a building owner/manufacturer. Evaluation by one of the *Designated Performance Evaluation Bodies* is required prior to approval by the Minister. The designation is done by the Minister, and 27 bodies (25 bodies located in Japan and 2 bodies located in foreign countries) have been designated, as of April 2012.

(b) In case of **large-sized buildings**, such as:

- wooden buildings or steel buildings with heights of 13 m or more, or eave heights of 9 m or more;
- reinforced concrete buildings with heights of 20 m or more; and
- steel structure buildings with four or more stories excluding the basement levels,

a building official and a *Designated Confirmation and Inspection Body* must ask one of the *Designated Structural Calculation Review Bodies* (*2) to perform a calculation review on the building plan before issuing a building confirmation.

<Exception>

Buildings coming under (a) are exceptions of Structural Calculation Review, because they are subject of Ministerial Approval.

(*2) Designated Structural Calculation Review Body

A *Designated Confirmation and Inspection Body* conducts a structural calculation review upon request by a building official or a *Designated Confirmation and Inspection Body*. The designation is done by the prefectural governors. This system was introduced in 2007, and **64 bodies** have been designated as of March 2010 in Japan.

(c) Structural design of **other buildings** are checked by a building official or a *Designated Confirmation and Inspection Body*.

Check of Structural Design

Buildings

- Building with more than 60 m in height, or
- Buildings using advanced structural calculation methods

- Large-sized Buildings**, such as:
- wooden buildings or steel buildings with height of 13 m or more;
 - reinforced concrete buildings with height of 20 m or more; and
 - steel structure buildings with four or more stories

Other buildings

Check of Structural Design

Performance evaluation
by the Designated
Performance Evaluation Body

Approval
by the Minister

Structural Calculation Review
by the Designated Structural
Calculation Review Body

Building Confirmation
by an Building Officer or the Designated Confirmation and Inspection Body

(5) Construction Work

The BSL and the *Kenchikushi* Law stipulate the provisions related to *construction administration*, as shown in the next page, so that designers design buildings and builders perform building construction in compliance with the technical requirements stipulated by the BSL.

Provisions related to *construction administration*

Construction work must be done in compliance with related provisions provided by the BSL and the *Kenchikushi* Law as shown in the next page.

Remark for the figure of the next page

The requirements indicated by (*) do not apply to the construction of small buildings (wooden buildings with not more than two stories and of no more than 100 m², and non-wooden buildings with not more than two stories and of no more than 30 m²).

Provisions related to *construction administration*

Designers - *Only Kenchikushi may design buildings.* (*) (the *Kenchikushi Law*)
- *Kenchikushi must design buildings in compliance with the technical requirements stipulated by the related laws.* (the *Kenchikushi Law*)

Builders - *Builders may only implement construction works that are designed by Kenchikushi.* (*) (the BSL)

Building owners - *The building owner must assign a Kenchikushi as a person who conducts construction administration.* (*) (the BSL)

Builders - *Builders must display the names of the designer* (*)*, the builder, the field manager and the person who conducts construction administration* (*), *in plain view on the construction site.* (the BSL)
- *Builders may only implement construction works for which a person who conducts construction administration is assigned.* (*) (the BSL)

A person who conducts construction administration

- When a person who conducts *construction administration* finds that the construction work does not follow the drawings/specifications made by a *Kenchikushi*:
 - *he/she must notify the builder immediately*; and
 - in cases where the builder does not follow his instructions, *he/she must report this to the building owner.* (the *Kenchikushi Law*)
- Once the construction work has been completed, He/she *must report the result to the inspector who conducts final inspection of the building.*

(6) Interim inspection

A building owner must, in a case where the construction work includes one of the processes in any of (a) and (b) below, and the process has been completed, request within four days from the date of completion, on all such occasions, an inspection by;

- a building official under the *Designated Administrative Agency* in charge of building control in that area; or
- one of the *Designated Confirmation and Inspection Bodies*.

(a) the process of installing steel bars of:
- the floor in the second floor; and
- beams supporting the said floor,
of apartment buildings with three or more stories. (See the right figure.)

(b) processes stipulated by the
Designated Administrative Agency

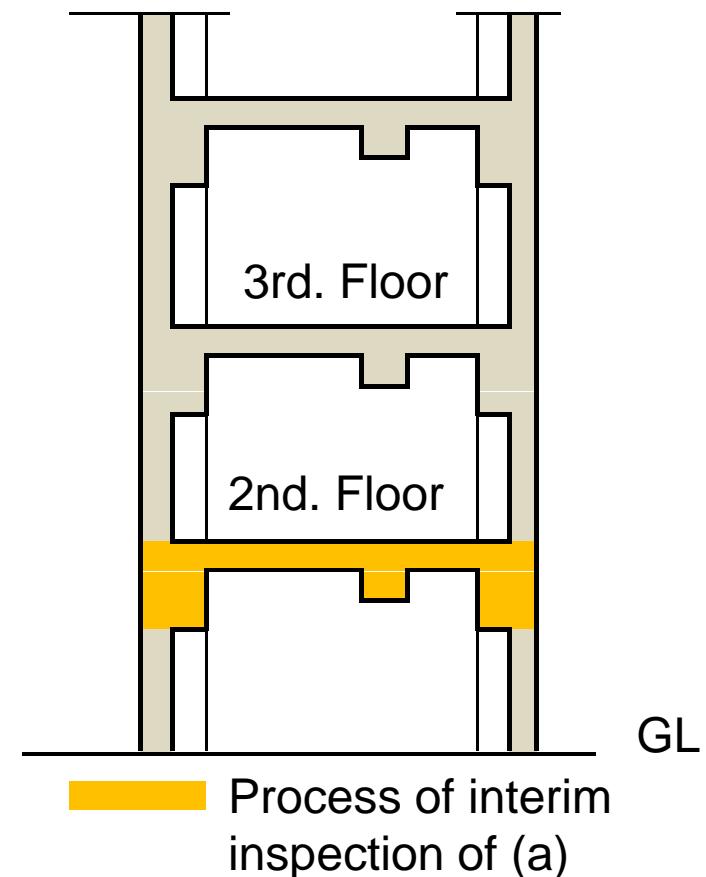

(7) Final inspection

Once the construction work has been completed, the building owner must submit a notification to;

- a building official under the *Designated Administrative Agency* in charge of building control in the area; or
- one of the *Designated Confirmation and Inspection Bodies*;

within four days from the date of completion. The building must undergo inspection to ascertain whether the building conforms to the related regulations.

(8) Occupancy

In cases where buildings are newly constructed, the building owner concerned must neither use nor let anyone use the building until he/she obtains an final inspection certificate.

Exception: in cases of any one of the following items, he/she may use or let someone use the building even before obtaining the certificate of inspection.

- (a) Small buildings, such as ordinal wooden detached houses of 2 stories or less.
- (b) Where the Designated Administrative Agency (or a building official after having received an application for a final inspection) has permitted temporary use after determining that there is no objection from the viewpoint of safety, fire prevention, or evacuation.
- (c) Where seven days have elapsed from the day on which the application for a final inspection was received.

The owner, custodian or occupant must endeavor to maintain the building and its site in a state complying with legal requirements.

(9) Periodic inspection report

The owners of the buildings and building equipment that the *Designated Administrative Agency* has designated must have thorough safety checks carried out at regular intervals (designated periods ranging from six months to three years) by *Kenchikushi* or other qualified people, and the results must be reported to the *Designated Administrative Agency*. Many *Designated Administrative Agencies* have designated;

- hospitals, hotels, department stores, theaters, apartment houses and offices, that exceeds a specific size; and
- elevators and escalators;

as buildings and building equipment to be reported.

3-5 Measures against buildings in violation

In cases where a building is in violation of the BSL, or orders and ordinances based upon it, *Designated Administrative Agencies* are empowered with the measures necessary to issue orders for:

- the suspension of construction work concerned; or
- the demolition, relocation, rebuilding, addition, repair, remodeling, prohibition or restriction of use of the building concerned; or,
- the implementation of other measures to correct violations against the said provisions or requirements;

to the building owner, or to the contractor or field manager of the construction work, or to the owner, custodian or occupant of the building or its site. In order to ensure the observance of the BSL, and orders and ordinances based upon it, various penal provisions are set out.

3-6 Declaration of dissatisfaction

According to the provisions of the BSL, a request for a review on the proceeding or nonfeasance of:

- a *Designated Administrative Agency*;
- a building official; or
- a *Designated Confirmation and Inspection Body*;

can be made to the *Building Review Council* of the local government concerned. In cases where the *Building Review Council* receives such a request, it is obliged to pass judgment, after a public hearing within one month after the receipt of the request. If there is any dissatisfaction with the judgment of the *Building Review Council*, an appeal against the judgment can be made to the Minister.

Contents

Chapter 4 Composition of the Building Codes

4-1 Performance-based codes

4-2 Alternative solution

4-3 Quality of materials

4-4 *Type Approval and Certification of Specific-type
Product Manufacturers*

4-1 Performance-based codes

(1) Historical background

(a) Before 2000

Japanese building regulations were largely a collection of specific provisions that dictate how a building must be built, including what materials can be used. And, when someone intended to use materials, equipments, design, or construction methods that did not meet specific provisions, he/she could not use them without special approval from the Minister.

(b) After 2000

As part of the 1998 revision of the BSL (enforced in June 2000), performance-based provisions were set up in the Building Codes in order to ensure:

- increased flexibility of performance-based design according to the Building Codes;
- correction of the distorted cost structure; and
- smooth introduction of technical innovations and materials from overseas.

And the new evaluation system was set up.

(2) Evaluation system

(a) Building materials/products/construction-methods

Building materials/products/construction-methods must meet technical requirements if the codes have specific mandatory standards that apply. It can be basically confirmed through either method below that they meet technical requirements.

- (i) To satisfy one of the specifications provided by the prescriptive provisions, including Ministerial Notifications, JIS (Japanese Industrial Standards) or JAS (Japan Agricultural Standards)
- (ii) To be approved by the Minister (It is needed to be evaluated by one of the *Designated Evaluation Bodies* (see **Remark**) prior to approval by the Minister.)

Innovative products, which do not satisfy one of the specifications provided by the prescriptive provisions, can be used if they are approved by the Minister through the process of (ii) above.

(b) Advance design methods

Buildings using advanced design methods are required that their safety be confirmed by a *Designated Performance Evaluation Body* (see **Remark**), and approved by the Minister.

Skyscrapers with more than 60 m in height are required that their structural safety be confirmed with advanced structural calculation methods, such as Time-series analysis.

Remark: *Designated Evaluation Body*

A *Designated Evaluation Body* conducts an evaluation to determine whether or not the solution meets performance requirements (performance criteria) upon request by a building owner/manufacture. Evaluation by one of the *Designated Evaluation Bodies* is required prior to approval by the Minister. The designation is done by the Minister, and **27 bodies** (25 bodies located in Japan and 2 bodies located in foreign countries) have been designated, as of April 2012.

Trends in Ministerial Approval

Number of approvals

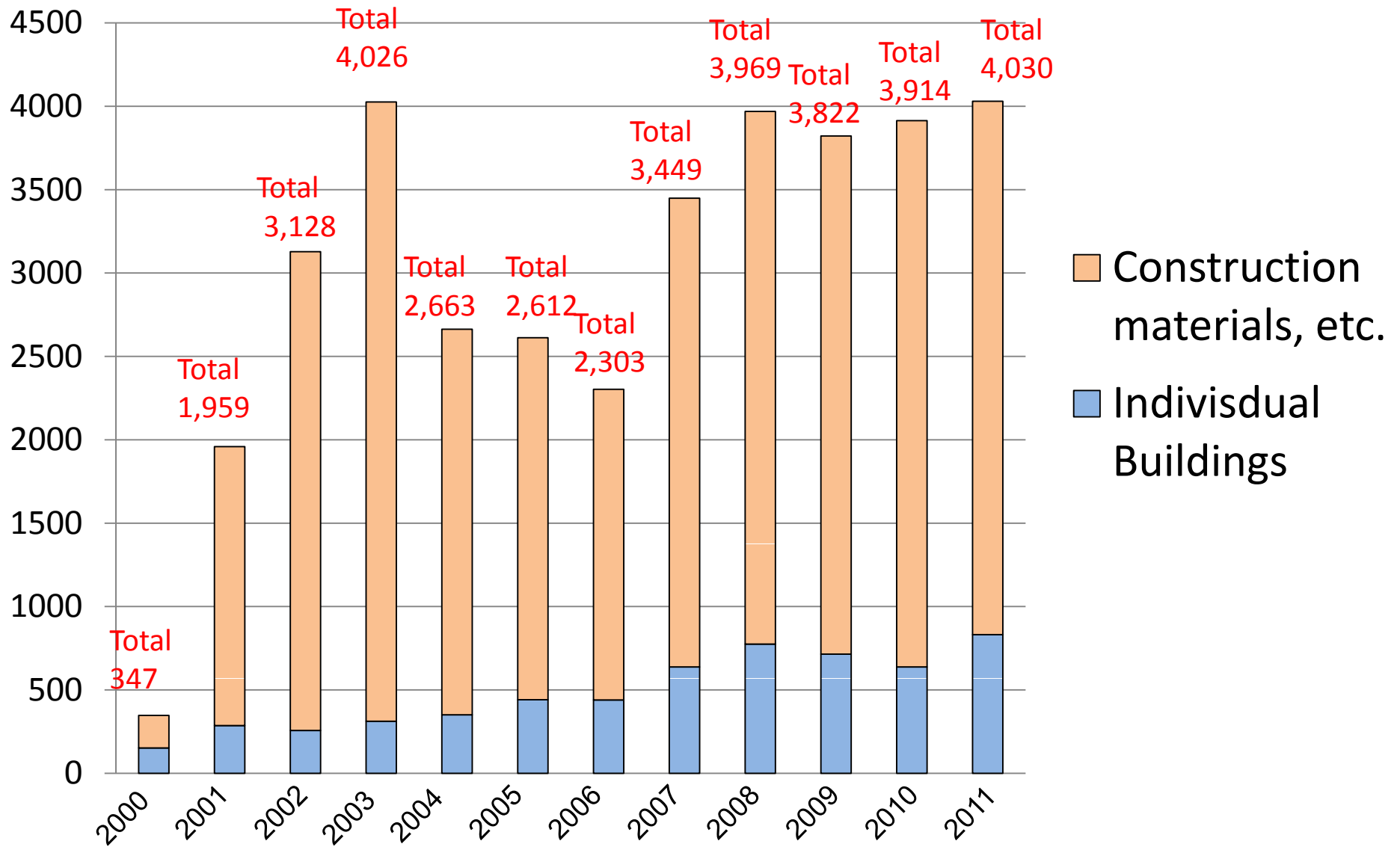

Fiscal Year (April to March of the next year)

4-2 Alternative solution

(1) Structure of alternative solution system

Based on the performance-based provisions set up in 2000, some alternative solution systems are established. The next page shows the alternative solution system for fire resistance, for example.

(Example) Alternative solution system for fire resistance

Performance Requirements

Example: Principal building parts must withstand the heat of a fire that could be expected to occur inside the building until the end of the fire. External walls must withstand the heat of a normal fire occurring in the area surrounding the building until the end of the fire.

Performance Standard

Example: When principal building parts are heated with the heat produced during a normal fire, the parts must not be deformed, melted, or cracked, nor must they undergo any other damage detrimental to structural strength.

Choice of the method

Specific provisions

To determine whether or not the solution meets one of the Sample Specifications

Example:

Principal building parts of reinforced concrete with required depth of concrete cover above steel bars are deemed to be fire-resistant.

Ordinary Verification Method

To determine whether or not the solution meets Performance Criteria through Ordinary Verification Method stated in the building Codes.

Example:

Principal building parts which are confirmed by the *fire resistance verification method* conform to *Fire-resistive performance criteria*.

Advanced Verification Method

To determine whether or not the solution meets Performance Criteria through Advanced Verification Method

Evaluation by a *Designated Performance Evaluation Body*

Approval by the Minister

Building Confirmation and inspection

The solution is checked through specific provisions.

The solution is checked through *Ordinary Verification Method*.

The solution is checked except the part already checked by the Minister.

(2) *Ordinary Verification Methods* and *Advanced Verification Methods*

Details of the *Ordinary Verification Methods* are stipulated in the *Enforcement Order* and in the *MLIT Notifications*. Examples are shown below. On the other hand, details of the *Advanced Verification Methods* are not issued by the Government. *Designated Performance Evaluation Bodies* evaluate the design/solution of a building, using a manual approved by the Minister, then the applicant sends the evaluation body decision, along with drawings, to the Minister to request approval.

(3) Fire-resistance Verification Method

The *Fire-resistance Verification Method* is a method based on technical standards, etc. provided in the *Enforcement Order* and in the *MLIT Notifications*, which is used to assume the occurrence of a fire in a room, and to verify that principal building parts can withstand the heat from the fire until the end of the fire. When fire-resistance is verified through this method, prescriptive requirements for fire-resistance are not applied to the solution. The stages are as follows:

(a) Calculation of fire duration;

The predicted time from the start of a fire until its end is calculated, considering the volume of combustible materials, the size of openings, etc.

(b) Calculation of heat-withstanding periods for principal building parts;

The periods over which principal building parts can withstand the heat by the fire are calculated, taking into consideration the type of structural methods used in the principal building parts, the heat of a fires, etc.

(c) Comparison of (a) and (b);

(b), heat withstanding period, must be longer than **(a)**, fire duration.

(4) Verification Method for Evacuation Safety

The *Verification Method for Evacuation Safety* is a method based on technical standards, etc. provided in the *Enforcement Order* and in the *MLIT Notifications*, which is used to check evacuation safety in fires by comparing:

(i) the predicted time required for the evacuation of persons in a building; with
(ii) the time during which the floors, or building, will be at risk from smoke and gas, etc, according to the design of the building (number of persons present, location of evacuation routes, fire and smoke prevention methods, etc.). When evacuation safety is verified through this method, some prescriptive requirements for evacuation safety are not applied to the solution. The stages are as follows:

(a) Calculation of time until completion of evacuation;

The evacuation time is calculated as a sum of:

- (i) the time from the outbreak of fire until the start of evacuation;
- (ii) the walking time to the exits; and
- (iii) the time lost at exits.

(b) Calculation of time required for smoke and gas to become a hazard;

The time is calculated for fire-related smoke and gas to descend from ceilings to reach a level at which they become hazards to evacuation, taking into account such factors as:

- (i) the floor area and ceiling height;
- (ii) the smoke exhaust assembly; and
- (iii) the types of materials used to finish the ceilings and walls.

(c) Comparison of (a) and (b);

(a), the time until completion of evacuation, must be shorter than **(b)**, the time when smoke/gas becomes a hazard.

4-3 Quality of materials

(1) Requirements on the quality of materials

When *Building materials designated by the Minister* (such as concrete, steel, and seismic isolation devices) are used for *Important building parts* (such as foundations, columns, bearing walls, and fire doors),

(a) these materials must conform to either *Japanese Industrial Standard (JIS)* or *Japanese Agricultural Standard (JAS)*, as specified by the Minister;

(b) otherwise they must be approved by the Minister.

In the case of (b), before application for ministerial approval, it is mandatory to have performance evaluations conducted by *Designated Performance Evaluation Bodies* based on the technical criteria concerning the respective materials, which are provided by the *MLIT Notification*.

Place to be installed Materials	<i>Important building parts</i> (See (2))	Others
<i>Building materials designated by the Minister</i> (See (3))	Materials must meet any of the followings: - Materials which conform to designated JIS* and JAS* - Materials which are approved by the Minister	Not regulated
Others	Not regulated	Not regulated

Remark: There are other provisions to state some requirements on building materials, such as requirements concerning fire resistance, formaldehyde, asbestos, and others.

(2) Important building parts concerning requirements on building materials

Important building parts from the viewpoint of structural safety, fire-safety or sanitation are defined as following items:

- (a) Elements necessary for **structural resistance**
- (b) **Parts of fire-resistive**, quasi fire-resistive, or fire-preventive construction
- (c) Opening fire-protective assembly specified in Article 109 or parts of these
- (d) Interior or exterior parts of buildings which are specified by the Minister as those important from the viewpoint of safety or fire-prevention
- (e) Partition walls, removable floor boards, floors of the lowest floor, small beams, pent roofs, small stairs for local use, outside stairs, balconies or other parts similar thereto, other than principal building parts which are specified by the Minister as those important from the viewpoint of fire-prevention
- (f) Building equipment or parts thereof (excluding equipments subject to certification as specified in the Fire Services Law, electrical appliances as defined in Article 2 paragraph 1 of the Electrical Appliance and Material Control Law, etc)

(3) Building materials designated by the Minister

Building materials designated by the Minister concerning requirements on building materials are following materials:

- (1) Structural **steel** and steel castings
- (2) High strength **bolts** and bolts
- (3) Structural cables
- (4) **Steel bars**
- (5) Welding materials (welding of carbon steel, stainless steel, and aluminum alloy)
- (6) Turnbuckles
- (7) **Concrete**
- (8) Concrete blocks
- (9) **Seismic isolation devices**
- (10) Wood-based glued axial material
- (11) Wood-based composite axial material
- (12) Wood-based composite insulated panel
- (13) Wood-based glued composite panel
- (14) Tapping screws and others similar thereto (limited to those with an internal thread formed on structural steel or those that cut and pass through structural steel.)
- (15) Fire bolt (referring to those driven into structural steel; same shall apply below)

- (16) Aluminum alloy
- (17) Mechanical joints for space frame structure
- (18) Membrane materials and membrane materials for tent warehouses
- (19) Ceramic masonry unit
- (20) Asbestos encapsulant
- (21) Prestressing Tendons
- (22) Autoclaved Light-weight aerated concrete panel

4-4 *Type approval and Certification of Specific-type Product Manufacturers*

At the same time that the performance-based provisions were added to the Building Codes, new systems of *Type Approval* and *Certification of Specific-type Product Manufacturers* were also created to decrease the burden on applicants and to improve the practicality of the examination process.

For example, many **prefabricated houses** share many of the same design features, and many buildings have much of the same type of equipment, such as mass-produced **elevators** and **water treatment facilities**. It is not practical to check these products in every building. Therefore, these systems were introduced.

Type approval and Certification of Specific-type Product Manufacturers

	<i>Type Approval</i>	<i>Certification of Specific-type Product Manufacturers</i>
Certification authority	<i>Designated Approval Bodies</i> (Eight bodies are designated by the Minister, as of April 2012.)	
Objects	building materials or building parts , such as building components and building equipments	
Certification	To confirm that the specifications meet the respective part of the Building Codes	To confirm that the manufacture supplies products with Type Approval through good quality management
Effects	<for building confirmation and on-site inspection > To be deemed to meet the respective part of the Building Codes through checking that they meet the specification of the approved type.	<for building confirmation > To be deemed to meet the respective part of the Building Codes through checking the certificate. <for on-site inspection > To be deemed to meet the respective part of the Building Codes through confirming that a person who conducts construction administration checked the construction work.

Contents

Chapter 5 Building Codes for Structural Safety

5-1 Composition of the structural codes

5-2 Structural specifications

5-3 Structural calculation methods

5-1 Composition of the structural codes

(1) Basic idea

The basic idea concerning structural safety is that structures must be safe against:

- (a) permanent load (dead load);
- (b) imposed load (live load);
- (c) snow load;
- (d) wind pressure;
- (e) seismic force; and
- (f) Others

(2) Concepts

In concrete terms, technical requirements have been set on the basis of the following concepts:

- (a) **The permanent load and imposed load** are safely supported, and cause no excessive deformation or vibration, which can interfere with the use of the building.
- (b) The building does not sustain damage due to a **rare medium-scale** snowfall, windstorm, earthquake, or other event.
- (c) The building does not collapse or otherwise fail due to an **extremely rare large-scale** snowfall, windstorm, earthquake, or other event.

(3) General Flow of Structural Design

(a) Structural Category of the buildings

Every building is classified into one of the categories:

- Category I (high-rise buildings);
- Category II (large-seized buildings);
- Category III (medium-sized buildings); and
- Category IV (small buildings),

based on the structural type, height, and size of the building, as shown in the table of 'Structural Category of the Buildings'.

Structural Category of the Buildings

Categories (share)	Structure, height, and size of building	
	Wooden buildings	Buildings other than wooden buildings
(I) High-rise buildings (0.1 %)	Building height > 60 m	
(II) Large-sized Buildings (2.5%)	<ul style="list-style-type: none"> - Building height > 13m, or - Eave height > 9m, other than (I) 	Any of the buildings below other than (I): <ul style="list-style-type: none"> - Steel buildings with 4 or more stories (excluding basement); - RC or SRC buildings of 20m or more in height, and - Buildings stipulated by the Cabinet Order, such as steel buildings more than 13 m in height or more than 9 m in eave height,
(III) Medium-sized buildings (25%)	<ul style="list-style-type: none"> - Number of stories > 3, or - Total floor area > 500 m² other than (I) and (II) 	<ul style="list-style-type: none"> - Number of stories > 2, or Total floor area > 200 m², and - Masonry structure, etc. that are more than 13m in height and that have eaves of more than 9m in height. other than (I) and (II)
(IV) Small buildings (over 70%)	Buildings other than (I), (II) and (III). It means wooden buildings that conform to: <ul style="list-style-type: none"> - Number of stories ≤ 2; - Total floor area ≤ 500 m²; - Building height ≤ 13 m; and - Eave height ≤ 9 m. 	Buildings other than (I), (II) and (III).

(b) Structural check responding to the Categories

There are **6 structural check combinations** (**A** through **F**, as shown in the figure 'Structural check responding to the Categories'. The order of sophistication of the combinations is from **A** (the highest), down to **F**.

For each category, the possible combinations to confirm its structural safety are determined as shown in the figure. **It is allowed to use more sophisticated combinations than the required combination.**

Some requirements of structural specifications are not applied to the combinations of **A**, **B**, and **C**, because these specific requirements can be checked through structural calculations of **A**, **B**, or **C**. Structural calculation or check for roofing material, etc. is done in the all combinations.

Structural check responding to the Categories

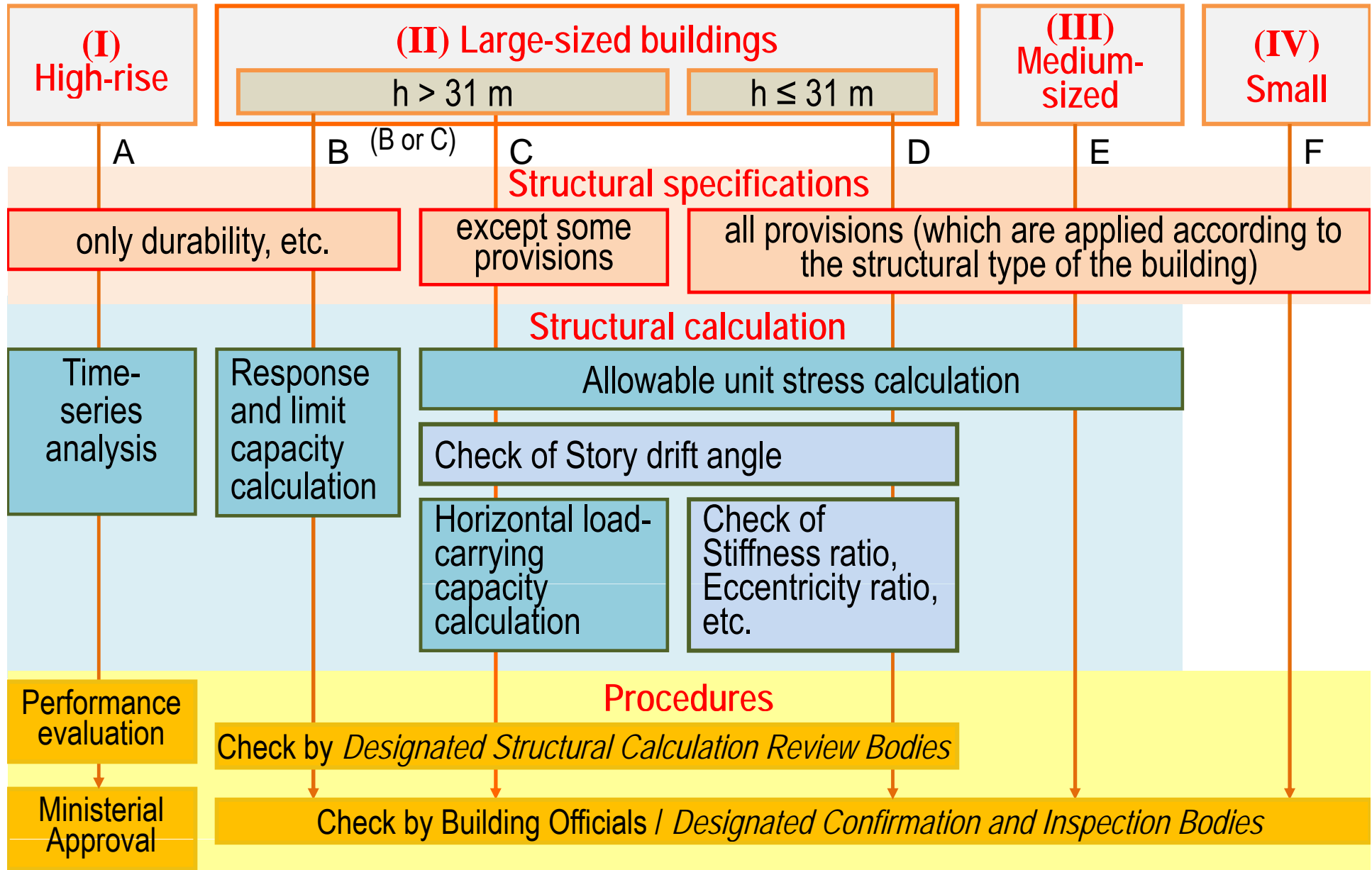

The order of sophistication of the combinations is from A (the highest), down to F. It is allowed to use more sophisticated combinations than the required combination.

- (i) **For Category IV (small buildings)**, it is required to only comply with structural specifications. Structural calculations are not required. On the other hand, it is allowed to use other structural combinations. In case where the structural safety of the building was confirmed by combinations of **A** or **B**, only the structural specifications on durability, etc. are applied to the buildings.

- (ii) **For Category II (large-sized buildings) and Category III (medium sized buildings)**, structural calculations are required. As same as Category IV (small buildings), in case where the structural safety of the building was confirmed by combinations of **A** or **B**, only the structural specifications on durability, etc. are applied to the buildings.

- (iii) **For Category I (high-rise buildings)**, only the combination **A** is allowed to use, and performance evaluation by a *Designated Performance Evaluation Body* and Approval by the Minister are required.

5-2 Structural specifications

Structural specifications are provided according to ordinary structural types, namely:

- wooden structures;
- masonry structures;
- reinforced concrete block structures;
- steel structures;
- reinforced concrete structures;
- steel and reinforced concrete composite structures; and
- plain concrete structures.

In addition, for:

- special structural methods of ordinary structural types mentioned above (such as wood-frame structure); and
- structural types other than ordinary structural types mentioned above (such as membrane structure),

structural specifications are established and announced in the form of *MLIT Notifications*.

(1) Wooden Structure

Concerning wooden structures, regulations are prescribed for:

- structure of sills and foundations;
- size of posts;
- necessary strength and quantity of braces and structural frames;
- methods of using joints/connection;
- quality of preservative measures; and
- others.

Here, the wooden structure refers to the post and beam structure, which is the conventional method of construction in Japan (see the next page), while the wood-frame structure comes under a different set of structural specifications. Structural specifications also exist for large wooden structures with posts and beams with large sectional size.

Structure of Conventional Japanese Wooden Houses

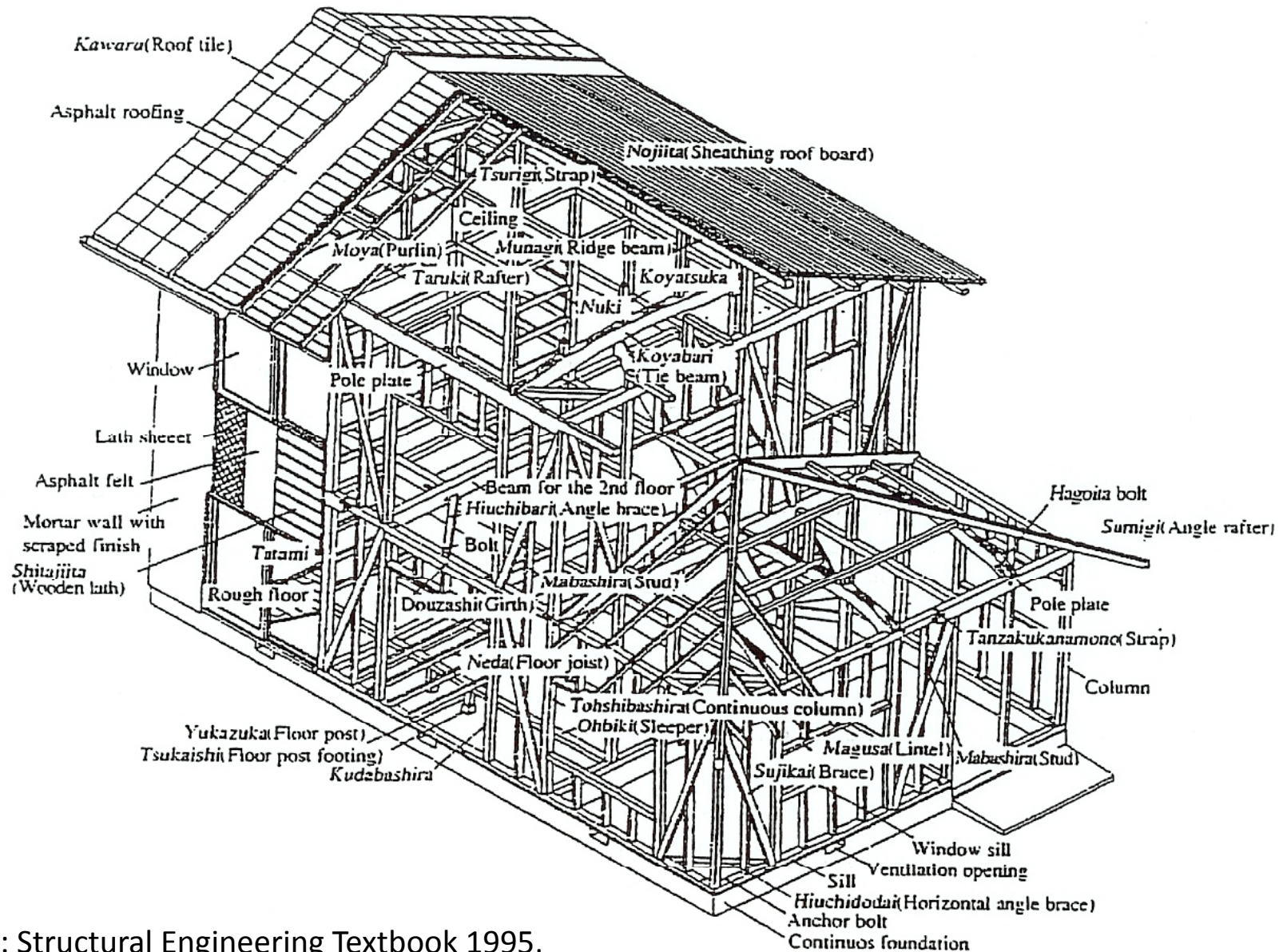

Source: Structural Engineering Textbook 1995,
Architectural Institute of Japan

(2) Masonry Structure

Concerning masonry structures, such as the brick structure and the stone structure, regulations are prescribed for:

- foundation structures;
- necessary length and thickness of walls;
- wall-girder structures;
- limitations on the size of openings;
- methods of construction work; and
- others.

(3) Reinforced Concrete Block Structure

This method of construction involves reinforcing bars passing through concrete blocks. Various regulations are provided for:

- foundation structures;
- necessary length and thickness of walls;
- size and arrangement of reinforcing bars;
- wall-girder structures;
- method of construction work;
- structural parts of fences; and
- others.

(4) Steel Structure

Regulations concerning the steel structure are provided for:

- effective slenderness ratio of members;
- foundation structures;
- methods of making joints and connections; and
- others.

(5) Reinforced Concrete Structure

Reinforced concrete structures are governed by regulations prescribing:

- quality of concrete materials;
- connections and arrangement of reinforcing bars;
- strength of concrete;
- method of curing;
- structure of columns, floor slabs, beams, and bearing walls;
- depth of concrete cover above steel bars; and
- others.

(6) Steel and Reinforced Concrete Composite Structure

Concerning steel and reinforced concrete composite structures, regulations for both steel structures and reinforced concrete structures are applied correspondingly, as the occasion demands.

(7) Plain Concrete Structure

Concerning plain concrete structures, regulations for both reinforced concrete structures and masonry structures are applied correspondingly, as the occasion demands.

(8) Other Structural Types

Technical standards for structural types other than those listed above are announced in the *MLIT Notifications*. Some of the technical standards have been announced for:

- wood-frame structures;
- pre-stressed concrete structures;
- box-frame type reinforced concrete structures; and
- others.

(1) Two-phase seismic design

Seismic codes revised in 1981 feature a two-phase seismic design for earthquakes.

(a) Primary seismic design

- For **medium-scale earthquake** motions (**Standard shear coefficient $C_o \geq 0.2$**)
Strong earthquakes which could occur several times during the life time of the building
- **Working stress < Allowable stress**
Not basically changed from the seismic design method before 1981)
- For **both superstructure and foundation**

(b) Secondary seismic design

- For **large-scale earthquake** motions (**Standard shear coefficient $C_o \geq 1.0$**)
Extraordinary earthquakes which could occur once in the life time of the building
- It requires **additional checking of several aspects** of the building that has been proportioned by the primary seismic design
- For **superstructure only**

Allowable unit stress calculation and other calculation methods

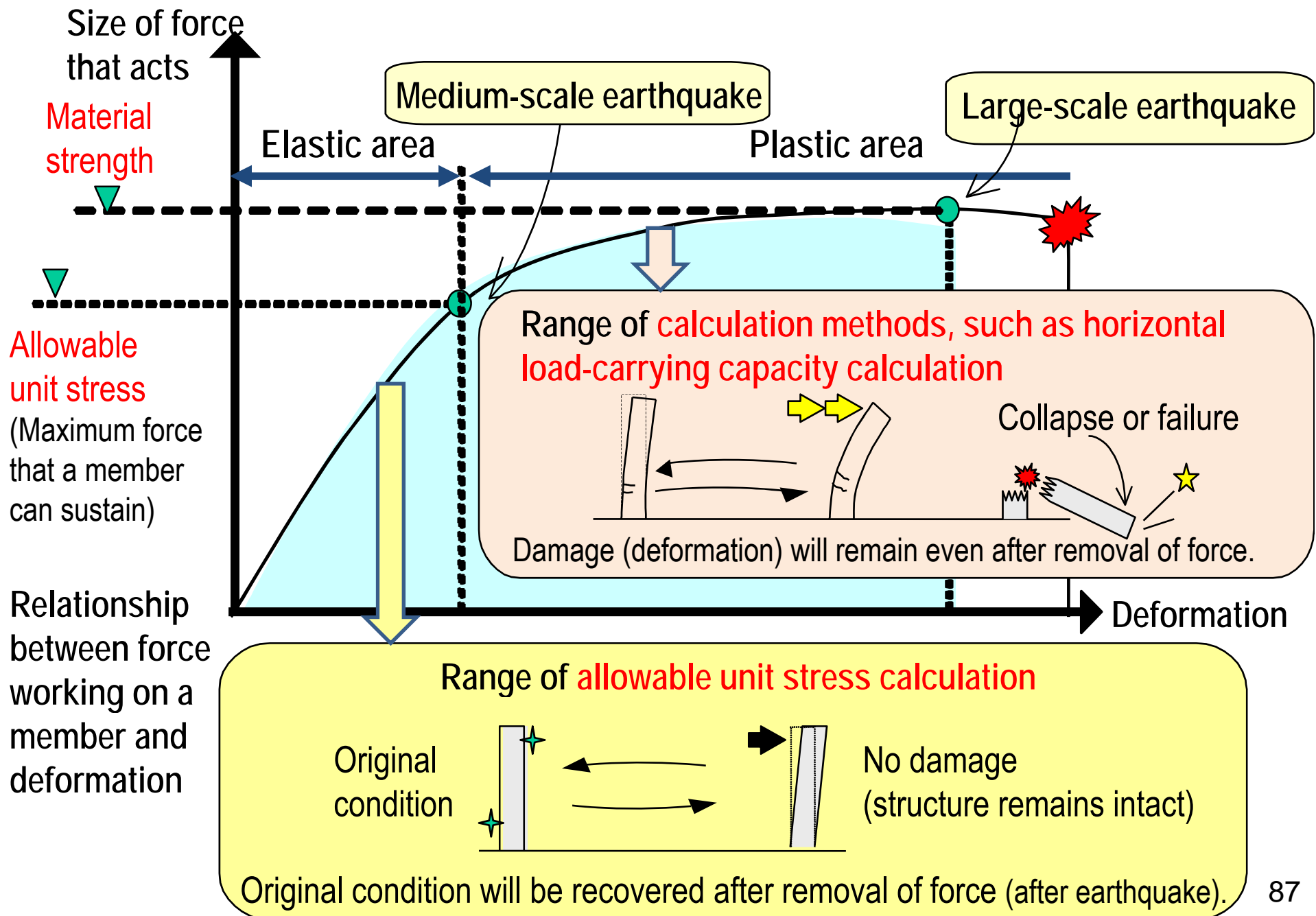

(2) Allowable unit stress calculation

(a) Calculation

Stresses acting upon the sections of elements necessary for structural resistance must be calculated by the formulas in the following table in cases both:

- sustained loads (for calculation considering normal time); and
- temporary loads (for calculation considering snow season, storm, or earthquake).

Kind of force	Possible conditions regarding loads and external forces	Loads and external forces, which must be included	
		General area	Heavy snow area
Force due to sustained loads	Normal time	G+P	G+P
	Snow season		G+P+0.7S
Force due to temporary loads	Snow season	G+P+S	G+P+S
	Storm	G+P+W	G+P+W
			G+P+0.35S+W
Earthquake	G+P+K	G+P+0.35S+K	

In this table, G , P , S , W and K represent the following loads and forces:

G : Permanent load (dead load);

P : Imposed load (live load);

S : Snow load;

W : Wind pressure; and

K : Seismic force.

(b) Confirmation

It shall be confirmed that sustained or temporary stresses do not exceed the allowable unit stresses in cases both sustained load and temporary load.

$$\text{Calculated stress} \leq \text{Allowable unit stress}$$

Values of allowable unit stress are available for common materials, such as timber, steel, concrete, etc. These values are specified for both sustained loads and temporary loads. Examples are shown in the next page. “Material strength” mentioned in the table is values of strength, which are used for calculations, such as horizontal load-carrying capacity calculation.

Examples of values of allowable unit stress and material strength

Concrete

		Compression	Tension
Allowable unit stress (Values of stress, which are used for allowable unit stress calculation)	Sustained load	$F/3$	$F/30$
	Temporary loads	$F/3 \times 2$	$F/30 \times 2$
Material strength (Values of strength, which are used for calculations, such as horizontal load-carrying capacity calculation)		F	$F/10$

F represents a specified design strength of concrete (unit: Newton/mm²), which is compressive strength to be set up in designing, and confirmed by the test of specimens.

Structural stainless steel

		Compression	Tension
Allowable unit stress (Values of stress, which are used for allowable unit stress calculation)	Sustained load	$F/1.5$	$F/1.5$
	Temporary loads	F	F
Material strength (Values of strength, which are used for calculations, such as horizontal load-carrying capacity calculation)		F	F

F represents a value of specified design strength (unit: Newton/mm²), which is specified by the Minister according to the kinds and quality of steel, etc.

(3) Loads and External Forces

Loads and external forces as factors for structural calculation vary, depending upon the location of the building and its use. Of these forces, at least five must be checked. They are:

- permanent load (dead load);
- imposed load (live load);
- snow load;
- wind pressure; and
- seismic force.

Depending upon the conditions, checks must also be performed for other external forces such as:

- ground pressure;
- water pressure;
- vibration; and
- shock.

(a) Permanent load (Dead load)

The permanent load is the load of each of the components of the building, including building equipment. It depends on the structural type of the building, finishing material of the components, etc. Various values are provided in the *Enforcement Order* for general cases. For special cases, the permanent load is determined according to the actual conditions.

(b) Imposed load (Live load)

The imposed load is the load of furniture, occupants, etc. It depends on the use of the building. Various values are provided in the *Enforcement Order* for general cases. For special cases, the imposed load is determined according to the actual conditions.

(c) Snow load

The snow load is determined by the method of calculation, below. Snow accumulation varies greatly from region to region in Japan because of the various meteorological conditions. Therefore, the *Designated Administrative Agencies* issue regulations to specify values, based on criteria specified by MLIT.

$$S = H \cdot R$$

S: Snow Load (N/m²)

H: Deepest snow fall in the region (cm), which is specified by regulation, issued by the *Designated Administrative Agency*

R: Unit snow load, which is 20 N/m²/cm, or the value specified by regulation, issued by the *Designated Administrative Agency*

The snow load used in calculations, however, can be decreased by increasing the degree of the roof slope. It can also be decreased in regions where snow is customarily removed from roofs.

(d) Wind pressure

The wind pressure that acts on a building depends on the shape and the height of the building. It is calculated by the velocity pressure multiplied by the wind force coefficient. The velocity pressure is generally calculated by the following formula:

$$q = 0.6 E V_o^2$$

q: Velocity pressure (N/m²)

E: Coefficient calculated using a method stipulated by the Minister, reflecting the roof height of the building and its surrounding environment

V_o: Standard wind velocity (m/s), as determined by the Minister

Wind force coefficients that are available for general cases are specified in the *MLIT Notification*.

(e) Seismic force

The seismic force is determined by calculating the inertial force that is generated through the movement of both the ground and the building. That is, horizontal force (seismic shear force) generated in the building. It is calculated by Formula A and Formula B below, incorporating the vibration characteristics of the building, the conditions of the ground, and other conditions.

Formula A: For seismic Force above the ground level

$$Q_i = W_i \cdot C_i$$

$$C_i = Z \cdot R_t \cdot A_i \cdot C_o$$

Q_i : the seismic shear force of point "i" (the height from ground level)

C_i : the seismic shear coefficient of point "i"

W_i : permanent load added to imposed load above point "i" (+ snow load, in heavy snow areas, as designated by the *Designated Administrative Agency*)

Z : the seismic zone factor (from 0.7 to 1.0)

R_t : vibration characteristic factor

A_i : vertical distribution factor

C_o : the standard shear coefficient

(a) In general cases, not less than 0.2 (not less than 0.3 within areas designated as soft ground areas)

(b) For calculating *required horizontal load-carrying capacity*, not less than 1.0

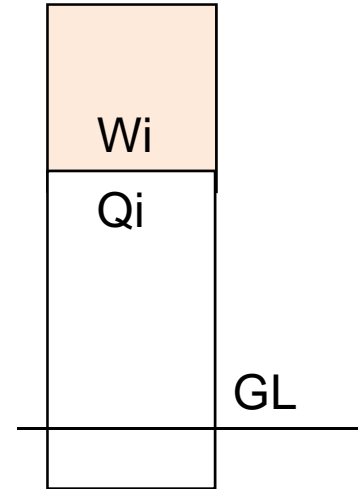

Formula B: For seismic force of the below-ground portion

$$Q_b = W_b \cdot k$$

Q_b : the seismic shear force

k : the seismic coefficient

$$k \geq 0.1 (1 - H/40) z$$

H = the depth of the portion below ground level (m) ($H \leq 20$)

z = the seismic zone factor (from 0.7 to 1.0)

W_b : permanent load added to imposed load above the portion

(4) Structural calculation methods other than Allowable unit stress calculation

High-rise buildings and large-sized buildings must be confirmed to be structurally safe through structural calculation methods shown in this part.

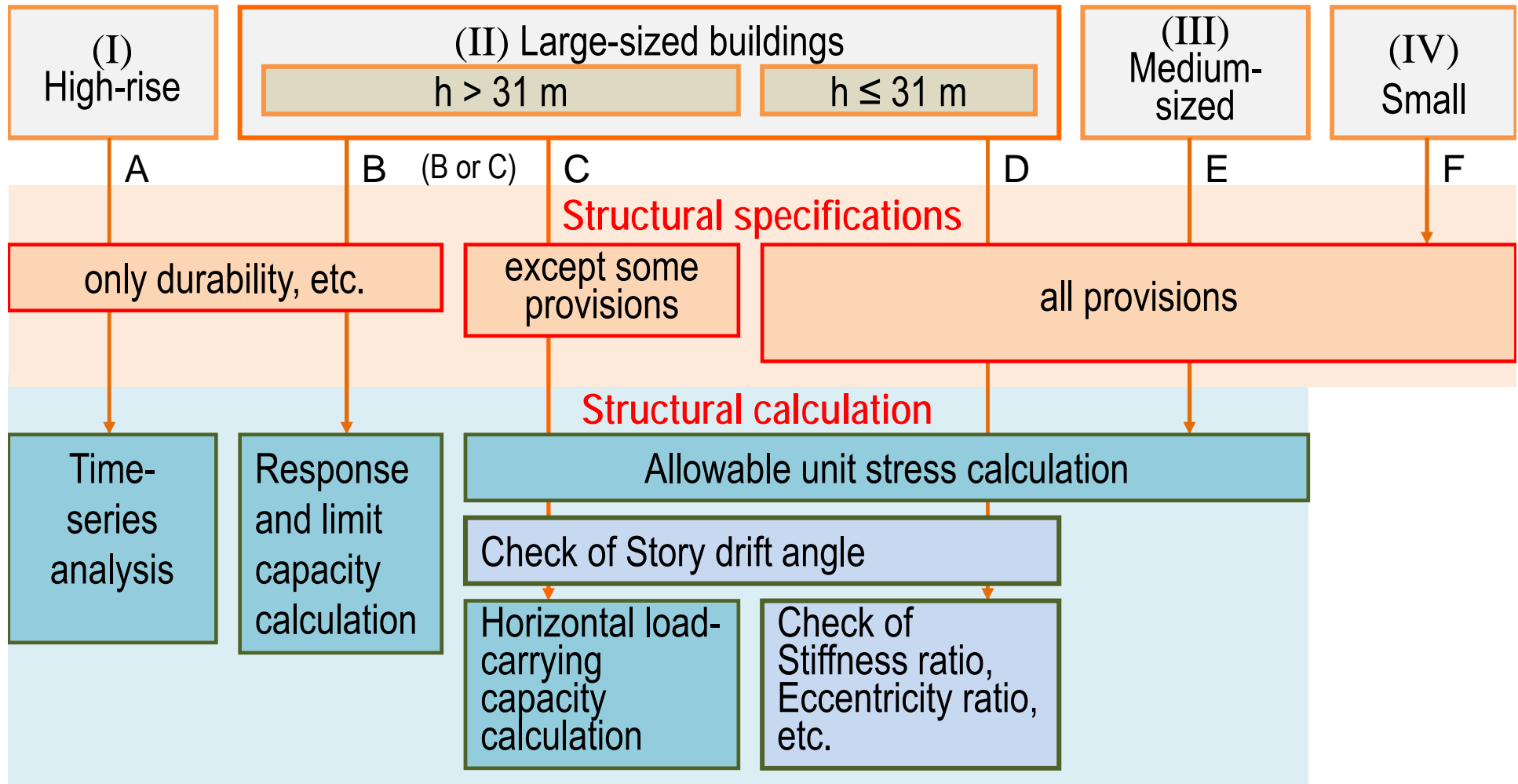

The order of sophistication of the combinations is from A (the highest), down to F. It is allowed to use more sophisticated combinations than the required combination.

(a) Story drift angle

This is to check that, during a mid-sized earthquake, **the horizontal deformation in each floor** (cross-section) is **within the scope wherein no external components become detached and fall from the building** (in principle, within 1/200, or 1/120 in cases where there is no fear of significant damage).

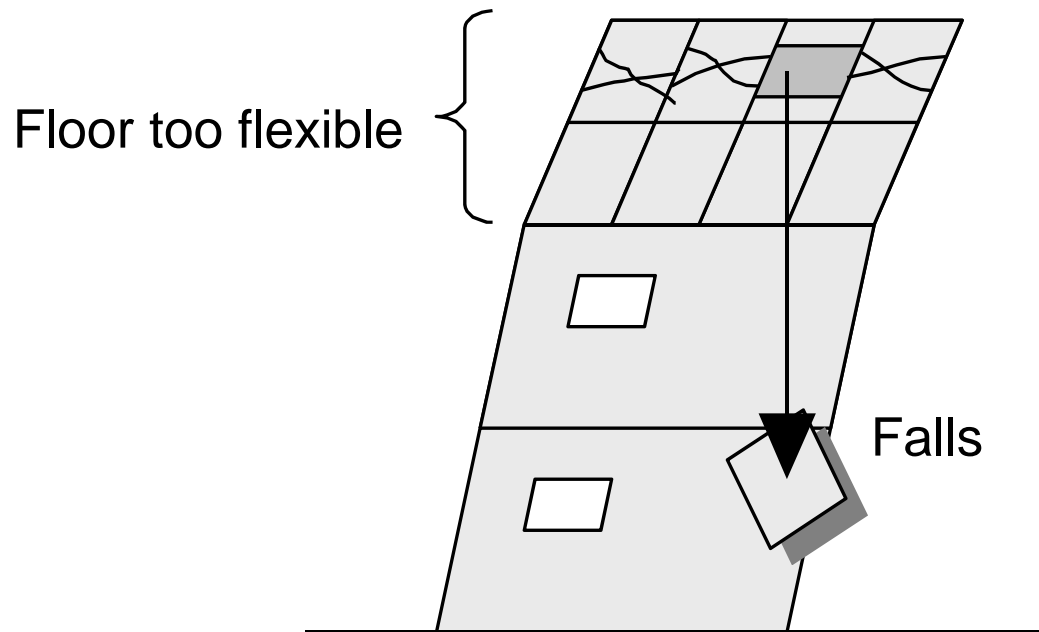

(b) Stiffness ratio and Eccentricity ratio

Stiffness ratio

Indicator of balance of hardness on each floor of building

《Vertical diagram》

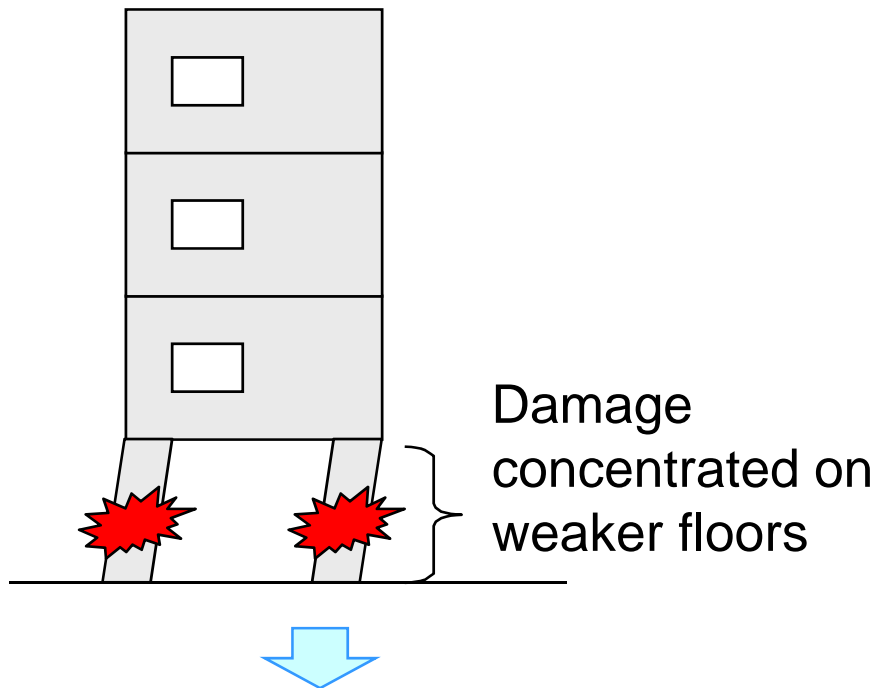

Eccentricity ratio

Indicator of balance of horizontal hardness on each floor

《Horizontal diagram》

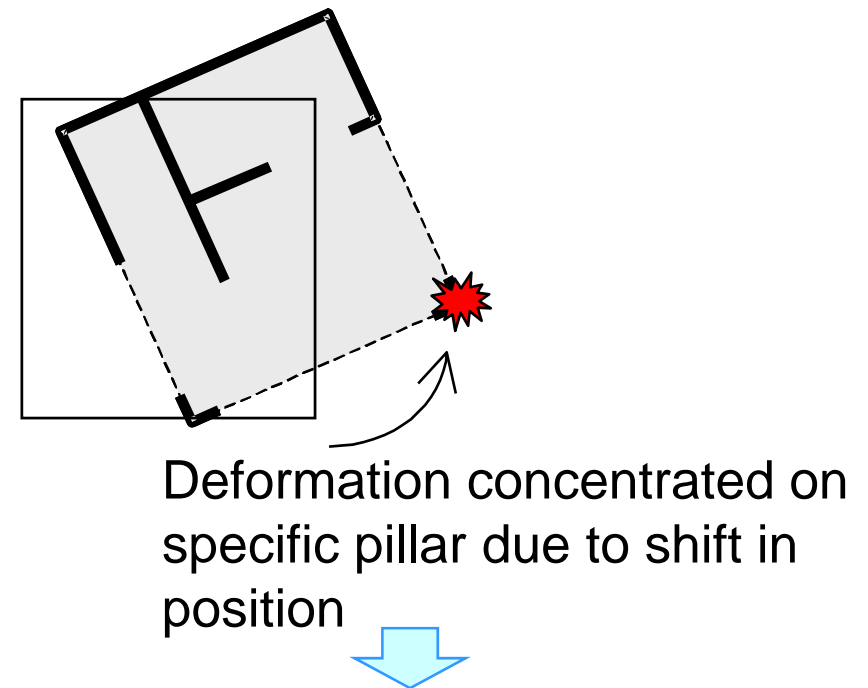

These calculations allow confirmation that the building's balance is within the scope that will not result in significant structural weakness

(c) Horizontal load-carrying capacity calculation

$$Q_u \geq Q_{un} \quad Q_{un} = D_s \cdot F_{es} \cdot Q_{ud}$$

Q_u : Horizontal load-carrying capacity of each story (unit: kilo-Newtons)

Q_{un} : **Required value** of horizontal load-carrying capacity of each story (unit: kilo-Newtons)

D_s : **Structural characteristics factor**, considering damping characteristics and ductility of each story

F_{es} : **Shape factor**, representing stiffness ratio and eccentricity ratio (up to 3.0 for irregular structure).

Q_{ud} : **Horizontal force** acting upon each story due to seismic force ($C_0 \geq 1.0$) (unit: kilo-Newtons)

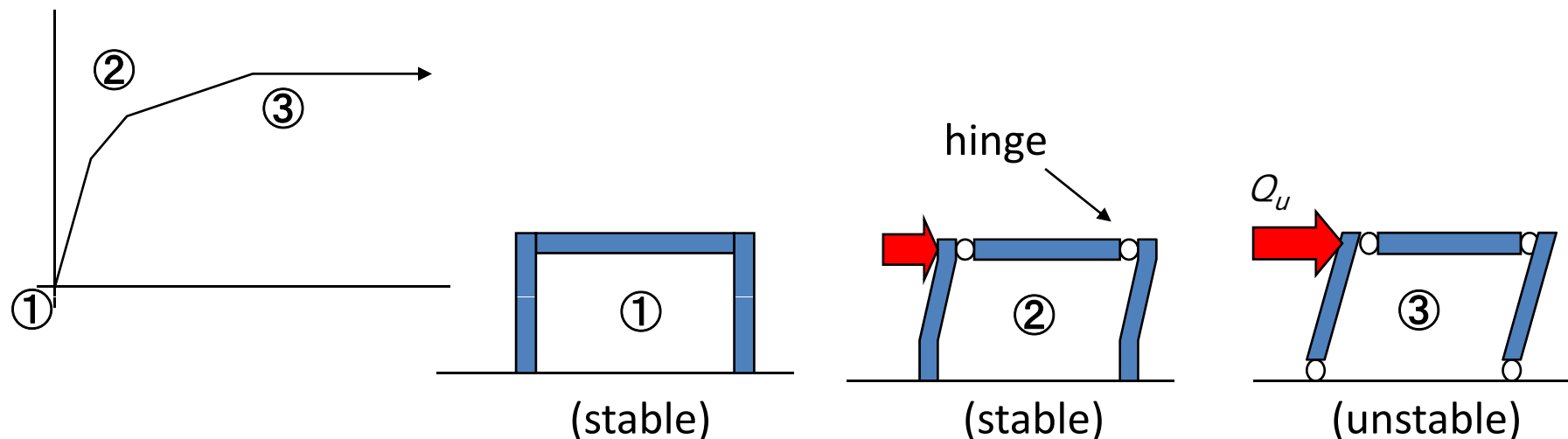

(d) Time-series analysis

- (i) To continuously clarify forces and deformation in each part of a building under loads and external forces, such as ground vibration caused by a large-scale earthquake, through the computer simulations.
- (ii) To confirm that forces and deformation clarified in (i) do not exceed the structural strength and deformation limit of each part of the building.
- (iii) To confirm that roofing materials, exterior finishing materials, and curtain walls facing the exterior are safe from the perspective of structural capacity due to wind pressure, earthquake, and other vibration and impacts.
- (iv) Others

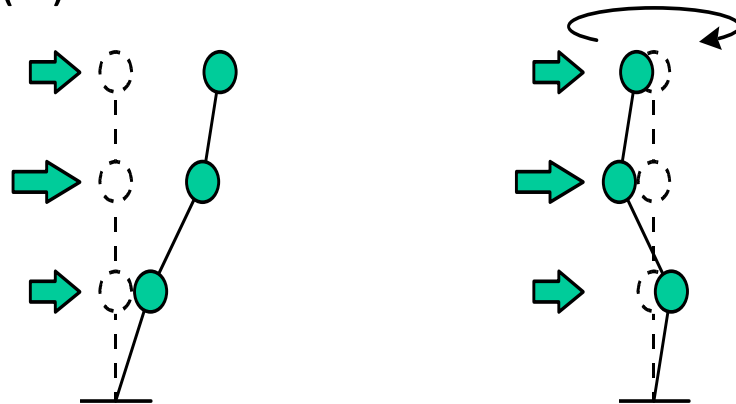

Ordinary analysis

Direction of deformation is always the same as that of external force .

Time-series analysis

Direction of deformation is not always the same as that of external force.

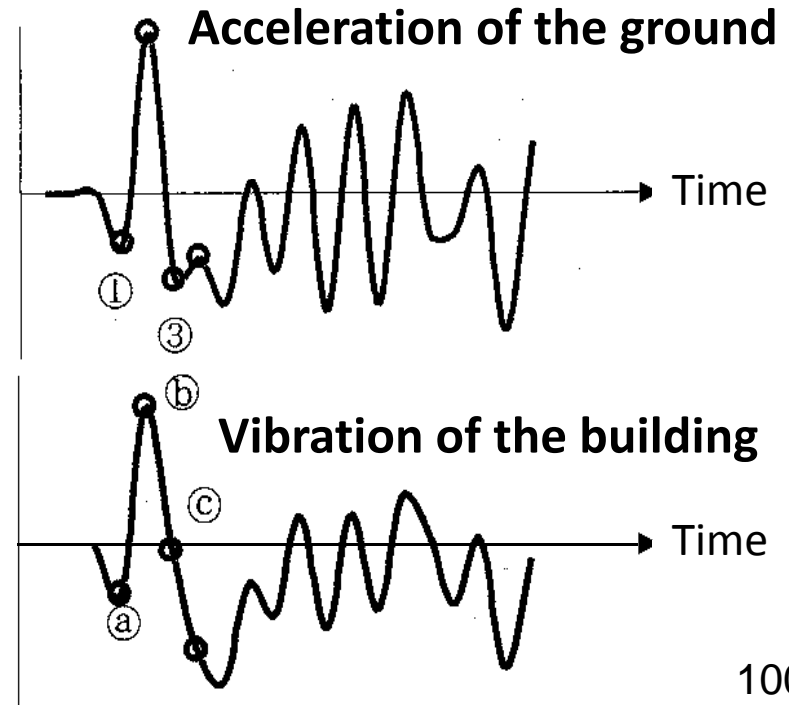

Contents

Chapter 6 Building Codes for Fire Safety

6-1 Composition of the fire codes

6-2 Definitions

6-3 Fire resistance

6-4 Fire compartment

6-5 External finishing

6-6 Internal finishing

6-7 Fire evacuation

6-1 Composition of the fire codes

The BSL and the Fire Service Law provide various technical requirements to secure fire safety in buildings. The examples of technical requirements provided by each of the BSL and the Fire Service Law are shown in the next page responding to the viewpoints of fire safety measures.

Technical requirements provided by the BSL and the Fire Service Law

Fire safety measures	Examples of technical requirements	
	The BSL (Regulates the basic structure and facilities of buildings)	The Fire Service Law (Regulates facilities and equipment from a fire safety viewpoint)
Prevention of the spread of fire from adjacent buildings	<ul style="list-style-type: none"> - Fire-resistance of roofing materials - Fire-resistance of external walls 	
Prevention of outbreak of fire	<ul style="list-style-type: none"> - Fire-resistance of interior finishing materials 	<ul style="list-style-type: none"> - Flame retardant curtains - Restrictions on appliances that operate with a flame
Fire detection		<ul style="list-style-type: none"> - Fire alarms
Evacuation	<ul style="list-style-type: none"> - Evacuation facilities, such as escape stairs - Smoke control systems 	<ul style="list-style-type: none"> - Escape facilities, such as escape ladders
Fire extinguishment and rescue	<ul style="list-style-type: none"> - Emergency elevators - Rescue access 	<ul style="list-style-type: none"> - Fire extinguishing equipment, such as automatic sprinkler systems and standpipe systems
Prevention of spread of fire within a building	<ul style="list-style-type: none"> - Fire compartments 	
Prevention of structural collapse	<ul style="list-style-type: none"> - Fire-resistance of principal building parts 	

6-2 Definitions

Definitions related to fire safety in the BSL are as below.

(1) *Noncombustible materials* (hereafter referred to as **NC**);

(2) *Quasi- noncombustible materials* (hereafter referred to as **Q-NC**); and

(3) *Fire retardant materials* (hereafter referred to as **FR**);

are building materials that conform to requirement (*1) during the time range shown in the next page, and that are either stipulated in the MLIT Notifications or that have been approved by the Minister on an individual basis.

(*1) Requirement for NC, Q-NC, and FR

When being heated with the heat of a normal fire, the material must satisfy the essential conditions in the following items (for those used as external finishing of the building, (a) and (b)) for the time as shown in **Table 12** after the beginning of the heating:

- (a) It must not cause burning.
- (b) It must not cause deformation, melting, cracking, or other damage detrimental to fire prevention.
- (c) It must not generate smoke or gas that is detrimental to evacuation.

NC, Q-NC, and FR

Material	Duration after heat is applied	Examples of materials deemed to satisfy the requirements for NC, Q-NC or FR
(1) NC	20 minutes or more	<ul style="list-style-type: none"> - Concrete, Mortar, and Lime plaster; - Bricks; - Pottery tile and Ceramic tile; - Steel and Aluminum; - Glass; and - Gypsum board with a thickness of 12 mm or more, and with a paper covering of a thickness of 0.6 mm or less
(2) Q-NC	10 minutes or more	<ul style="list-style-type: none"> - NC; - Gypsum board with a thickness of 9 mm or more, and with a paper covering of a thickness of 0.6 mm or less; and - Wood wool cement board with thickness of 15 mm or more
(3) FR	5 minutes or more	<ul style="list-style-type: none"> - NC and Q-NC; and - Gypsum board with a thickness of 7 mm or more, and with a paper covering of a thickness of 0.5 mm or less

NC: *Noncombustible materials*

Q-NC: *Quasi- noncombustible materials*

FR: *Fire retardant materials*

- (4) *Parts liable to catch fire*** are parts of a building within a distance of 3 m for the first floor, or 5 m for the second or higher floors, from any of the following:
- (a) the boundary line with the adjacent land lot;
 - (b) the center line of the road;
 - (c) the center line between exterior walls of two or more buildings on the same site (two or more buildings with an aggregate total floor area not exceeding 500 m² are regarded as one building).

(see the figure on the right)

However, any part facing an open space or a water area that is effective for fire safety, such as a park, public square, river, or facing walls of fire-resistive construction, or the like, are not considered *parts liable to catch fire*.

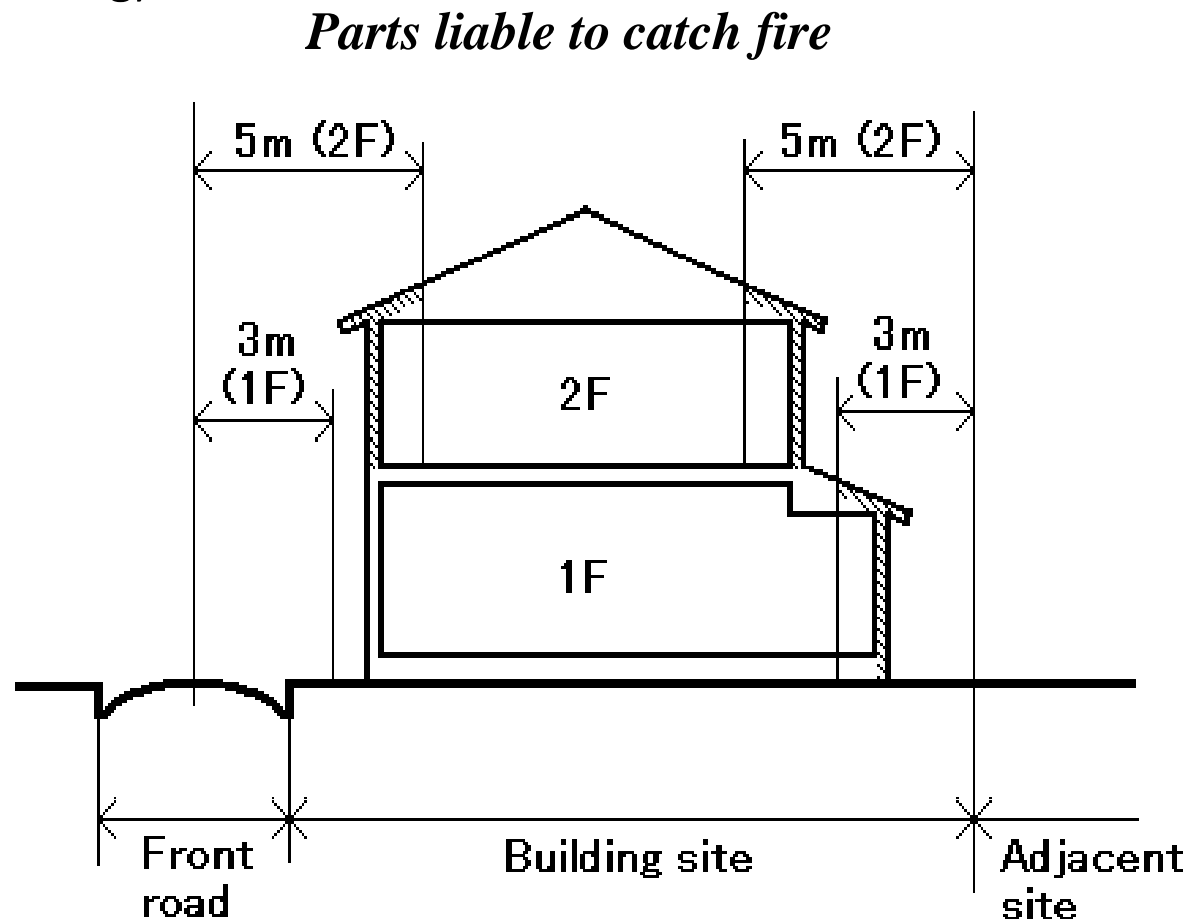

(5) Fire-resistive buildings are defined as buildings:

(a) of which **principal building parts** (namely, those walls, posts, beams, roofs, and stairways that are important from the viewpoint of fire prevention):

(i) come under **fire-resistive construction** (see **(6)**); or

(ii) are constructed using a solution that has been confirmed to be capable of withstanding fire and heat until the end of a fire through:

- **Fire-resistance Verification Method** (see **4-2 (3)**); or

- **Approval from the Minister**; and

(b) of which openings in *parts liable to catch fire* are equipped with certain *fire-preventive assemblies*.

(6) *Fire-resistive construction* is defined as a building part, such as walls, columns, beams and floors, which conforms to technical criteria of ***fire-resistive performance*** (*1), and:

- (a) Which uses **construction methods established by the Minister** (*2); or
- (b) Which is **approved by the Minister** (*3).

(*1) *Fire-resistive performance*

Technical criteria of *fire-resistive performance* are shown in the table of the next page (with some other requirements). Building parts of fire-resistive construction must not be deformed, melted, cracked, or undergo any other damage detrimental to structural resistance during the times as listed in the table after the heating begins, when they are heated with heat produced by a normal fire.

(*2) *Construction methods established by the Minister*

Common construction methods of building parts of *fire-resistive construction* have been specified by the Minister. They are deemed to have *fire-resistive performance* during the times as listed in the table. Their examples of reinforced concrete structure are shown in the table of the page after the next.

(*3) *Approval by the Minister*

Other than the common construction methods, construction methods of building parts, which the Minister approved that they have *fire-resistive performance*, may be used as *fire-resistive construction*.



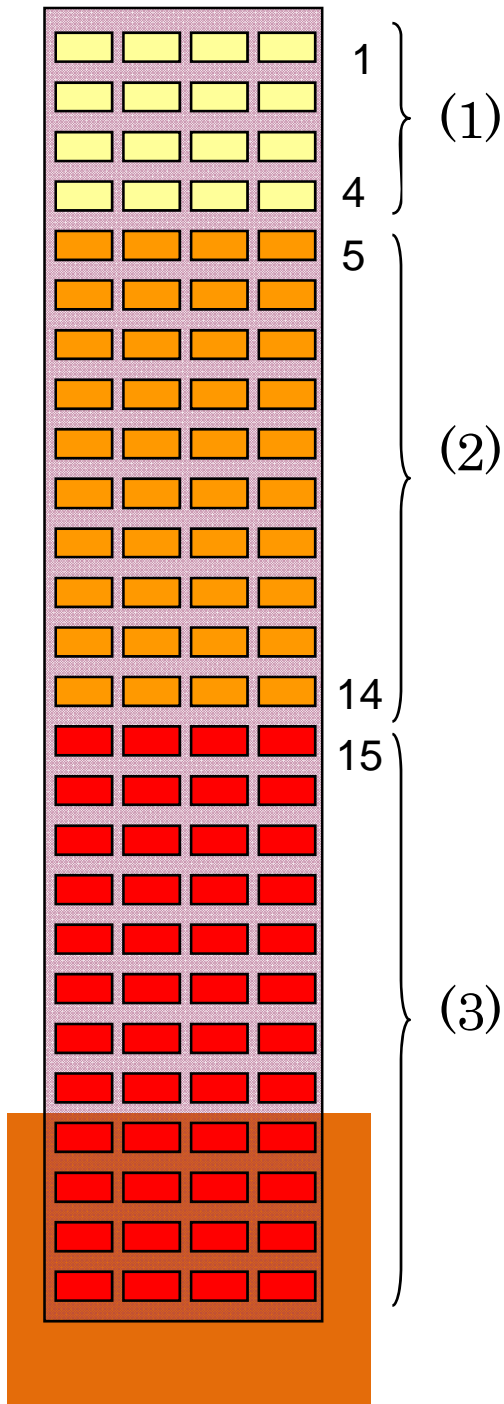



Technical criteria of *Fire-resistive performance* required on the building parts of *fire resistive construction*

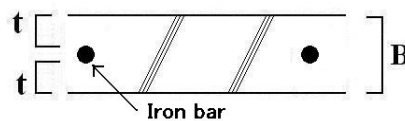
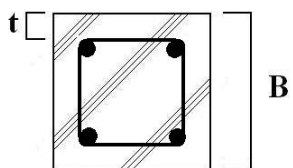

Story	(1)	(2)	(3)
Parts	Uppermost story and second to fourth stories from the uppermost story	Fifth to fourteenth stories from the uppermost story	Fifteenth story or more from the uppermost story
Load bearing walls	1 hour	2 hours	2 hours
Columns	1 hour	2 hours	3 hours
Floors	1 hour	2 hours	2 hours
Beams	1 hour	2 hours	3 hours
Roofs	0.5 hour		
Stairs	0.5 hour		

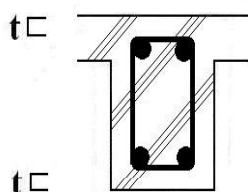
Example of building parts of *fire-resistive construction* (in case of reinforced concrete structure)

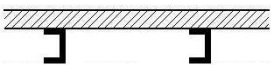
In case of steel structure, fire-preventive covering is required.

	Required times (*)	Required conditions, such as depth of concrete cover above steel bars	
Load bearing walls	60		$B \geq 70 \text{ mm}, t \geq 30 \text{ mm}$
	120		$B \geq 100 \text{ mm}, t \geq 30 \text{ mm}$
Columns	60		$t \geq 30 \text{ mm}$
	120		$B \geq 250 \text{ mm}, t \geq 30 \text{ mm}$
	180		$B \geq 400 \text{ mm}, t \geq 30 \text{ mm}$
Floors	60		$B \geq 70 \text{ mm}, t \geq 20 \text{ mm}$
	120		$B \geq 100 \text{ mm}, t \geq 20 \text{ mm}$
Beams	60		$t \geq 30 \text{ mm}$
	120		$t \geq 30 \text{ mm}$
	180		$t \geq 30 \text{ mm}$
Roofs	30	 RC structure  Roof covered with concrete finish	
Stairs	30	 RC structure  Steel structure	

(*) Minutes, which are required on each building part (See the preceding page.)

(7) Quasi fire-resistive buildings are defined as buildings:

(a) of which construction method meets any of following:

(i) *Principal building parts* come under *quasi fire-resistive construction*

Type of quasi fire-resistive construction (see **Figure of Type A**)

Type of 1-hour quasi fire-resistive construction

(ii) Buildings are constructed using a construction method specified in the *MLIT Notification*.

Type of fire-resistive external walls (see **Figure of Type B-1**)

Type of NC (Noncombustible materials) (see **Figure of Type B-2**)

(iii) Buildings are constructed through a solution approved by the Minister.

Type of Ministerial approval

and

(b) of which openings in *parts liable to catch fire* are equipped with certain *fire-preventive assemblies*.

Remark: The definition of *quasi fire-resistive buildings* does not include *fire-resistive buildings*.

Quasi fire-resistive building

Type of quasi fire-resistive construction (Type A)

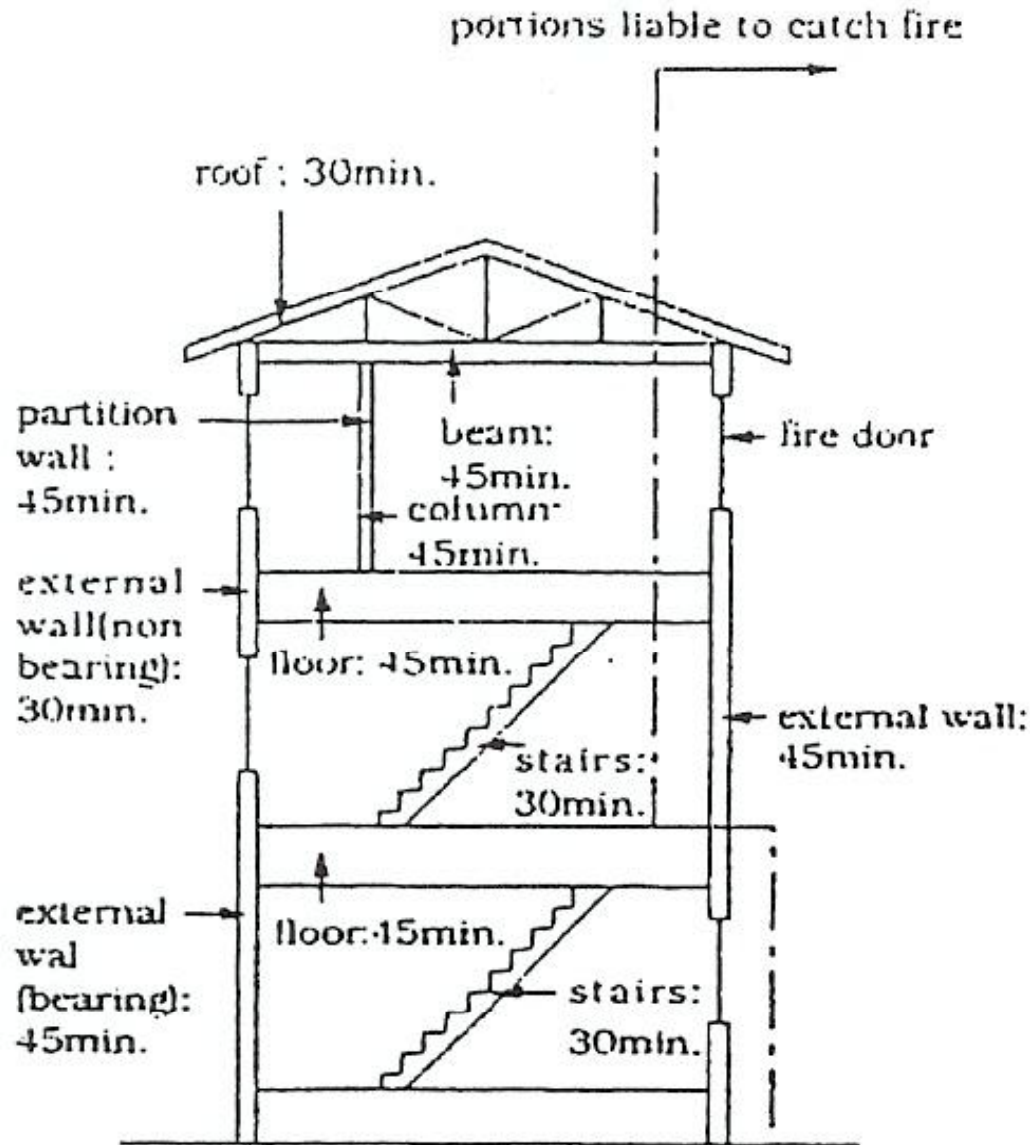

Remarks:

- (1) NC: *Noncombustible material*
- (2) Q-NC: *Quasi-noncombustible material*
- (3) Time shown in the figures indicates the duration of time for which components of quasi fire-resistive buildings must be able to withstand fire.

Quasi fire-resistive building

Type of fire-resistive external walls (Type B-1)

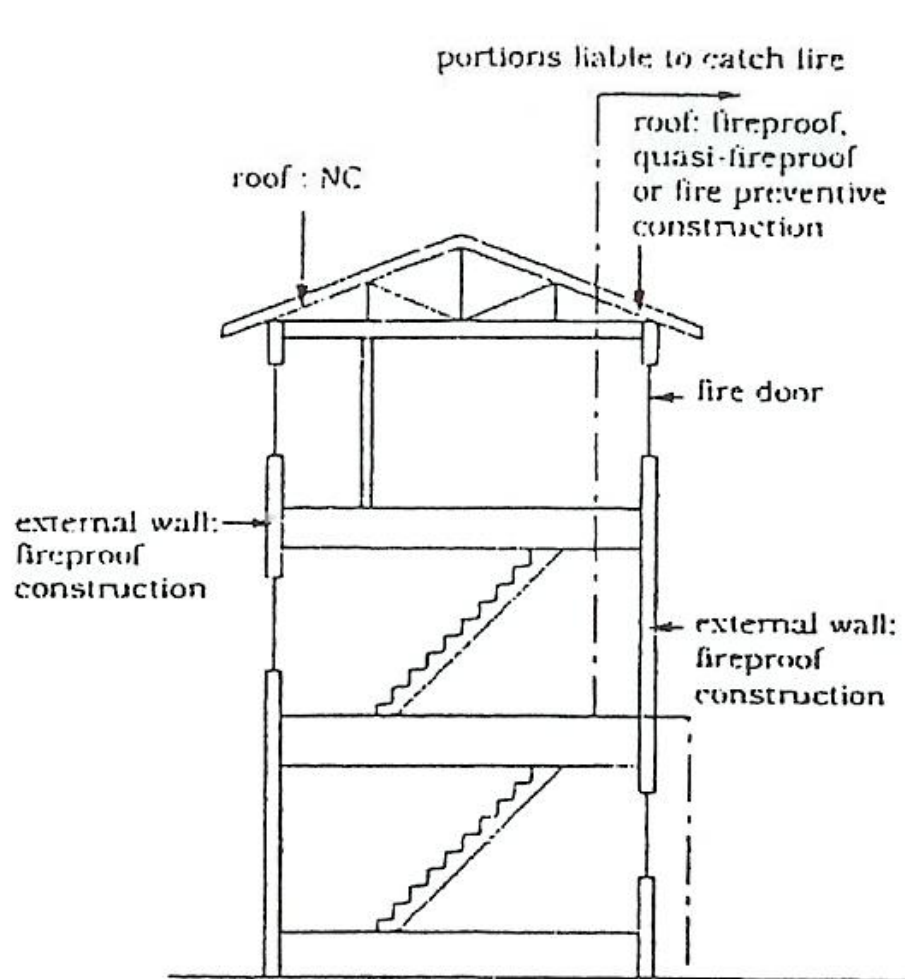

Type of NC (Noncombustible materials) (Type B-2)

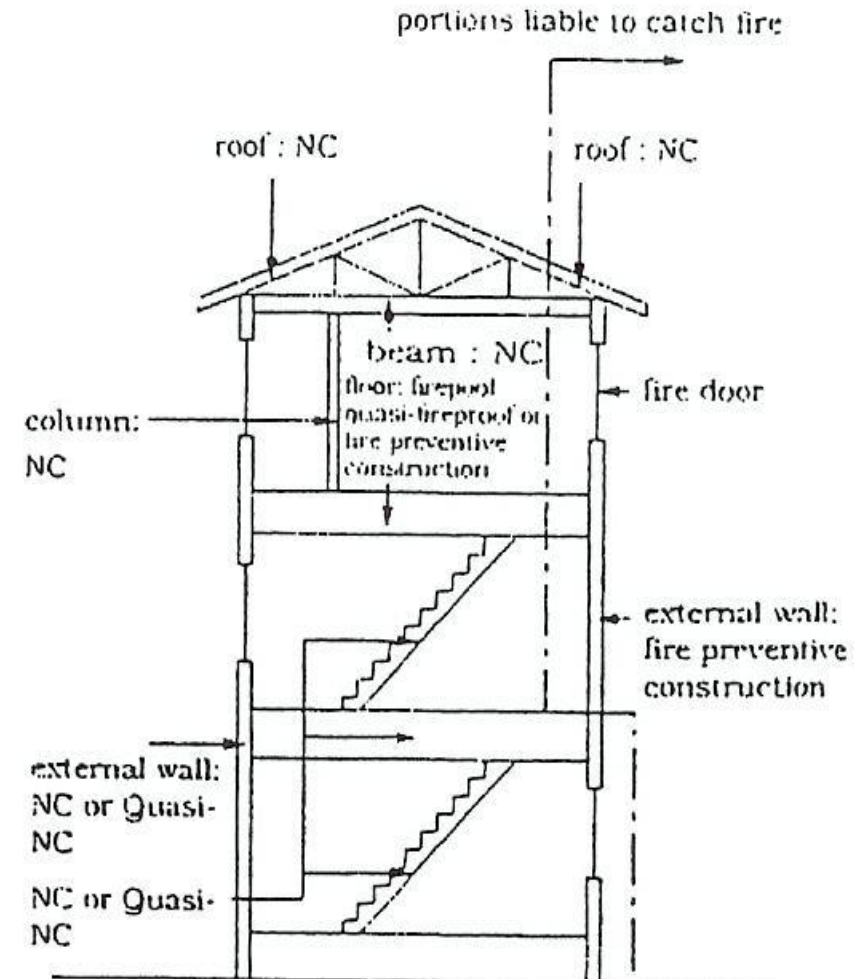

(8) Fire-protection Zone and Quasi Fire-protection Zone are zoning systems provided by the City Planning Law. These zones are designated in urban areas in order to prevent the spread of fire from building to building. In the major cities of Japan, these zones are designated over a large area. Extensive measures for fire safety are required in the designated zones by the BSL.

(9) Zone based on Article 22 are the urban areas designated by the *Designated Administrative Agencies*, based of Article 22 of the BSL for the purpose of prevention of the spread of fire in urban areas.

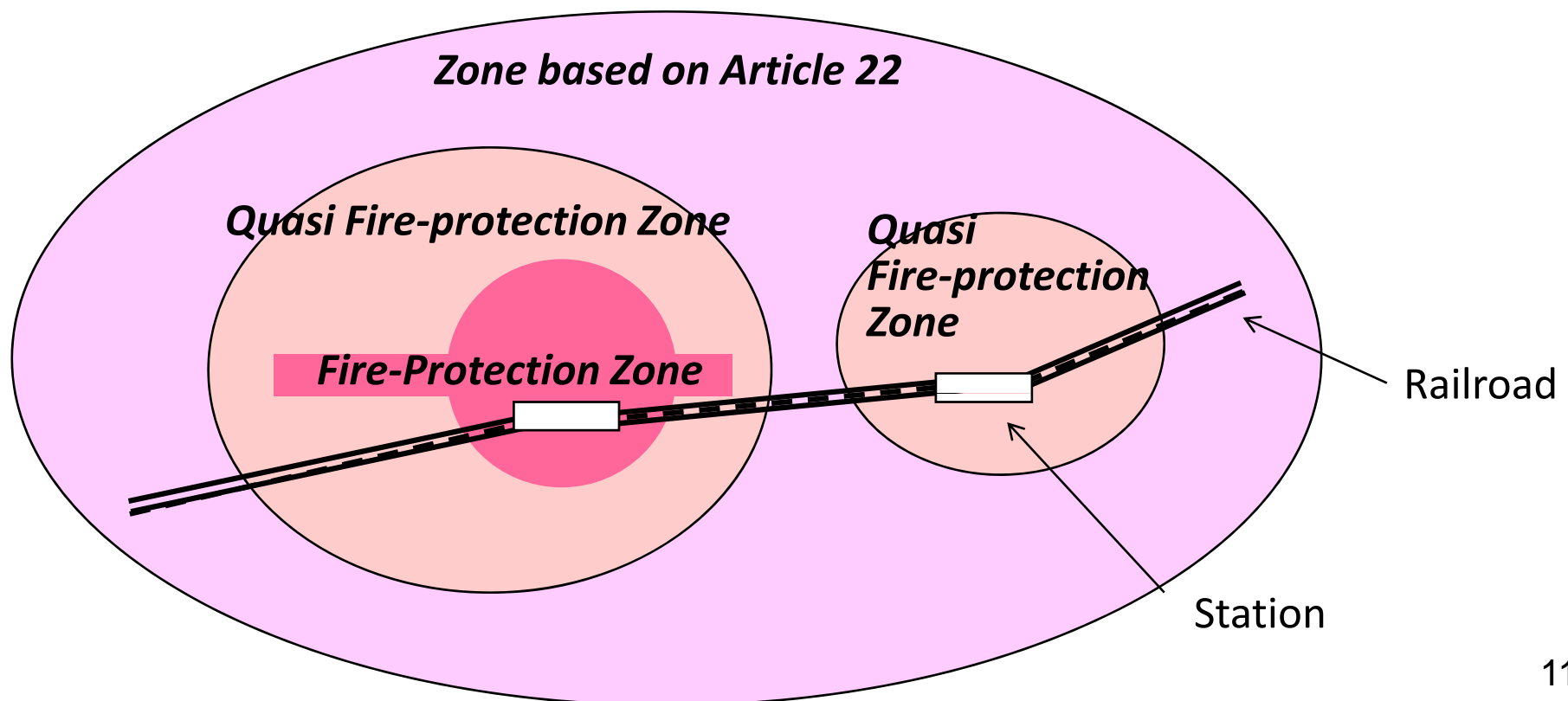

6-3 Fire resistance

In order to:

- secure the time for evacuation,
- prevent collapse, and
- prevent catching fire,

fire resistance is required on buildings from three characteristics of buildings as follows:

- (1) Scale of the buildings;
- (2) Use of the buildings; and
- (3) Location of the buildings.

(1) Restrictions on Large-scale *Buildings*

In case of buildings,

- (i) which are more than 13 m in building height, more than 9 m in eave height, or more than 3000 m² in total floor area, and
- (ii) of which bearing walls, posts, or beams are made of combustible materials, such as wood and plastic,

their safety of fire resistance must be confirmed by:

- (i) using materials that the Minister approved as *fire-resistive construction*; or
- (ii) using solution that has been confirmed to be capable of withstanding fire and heat until the end of a fire through:
 - *Fire-resistance Verification Method* (see **4-2 (3)**); or
 - Approval by the Minister.

Some construction methods, of which structural members are wood covered by gypsum boards, have been approved by the Minister as *fire-resistive construction*, which is considered to be able to undergo the fire for one hour.

(2) Restrictions on Construction of *Special Buildings*

Special buildings are defined as, but not limited to:

- (a) buildings that are intended to be used by many and unspecified people, such as theaters, grandstands and department stores; and
- (b) as buildings where many people sleep, such as apartment houses, hotels and hospitals.

It is prescribed that certain sizes of these *special buildings* must be *fire-resistive buildings*, and other certain sizes of these *special buildings* must be either *fire-resistive buildings* or *quasi fire-resistive buildings*. (see the following four pages)

Fire Resistance of Special Buildings (1/3)

Grade of building required Use		Fire-resistive building (in case of (1) or (2))		Fire-resistive building or Quasi fire-resistive building
		(1)	(2)	
1	-Theaters - Movie theaters - Entertainment halls	The main floor is not on the 1st floor	Seating space is 200 m ² or more. (In case of open-air stand, 1,000 m ²)	-
	-Grandstands -Public halls - Assembly halls	Third or higher floors is used for any of these uses.		
2	-Hospitals -Clinics (limited to those having patient accommodation facilities) -Hotels/inns -Boarding houses -Apartment houses -Dormitories - <i>Welfare facilities(*1)</i>	The third floor or higher is used for any of these uses. (*2)	-	Floor area for the use on the 2nd floor is 300 m ² or more. (For hospitals, this only applies to buildings which have patient accommodation facilities on the 2nd floor.)

Fire Resistance of *Special Buildings* (2/3)

Use		Grade of building required	<i>Fire-resistive building</i> (in case of (1) or (2))		<i>Fire-resistive building or Quasi fire-resistive building</i>
			(1)	(2)	
3	<ul style="list-style-type: none"> - Schools - Gymnasia - Museums, Art museums - Libraries - Bowling alleys, Indoor ski slopes, Skating rinks, Swimming pools, Sports practice facilities 		The third floor or higher is used for any of these uses.	-	The total floor areas for the use is 2,000 m ² or more.
4	<ul style="list-style-type: none"> - Department stores, Markets - Exhibition halls - Cabarets, Cafes, Night clubs, Bars, Dance halls, Amusement halls - Public bathhouses - <i>Machiai</i>, Restaurants, Dining facilities, - Stores engaged in commodity sales (excluding those with a floor area of 10 m² or less) 		The third floor or higher is used for any of these uses.	The total floor areas for the use is 3,000 m ² or more.	The floor area for the use on the 2nd floor is 500 m ² or more.

Fire Resistance of *Special Buildings* (3/3)

Grade of building required Use		<i>Fire-resistive building</i> (in case of (1) or (2))		<i>Fire-resistive building</i> or <i>Quasi fire-resistive building</i>
		(1)	(2)	
5	- Warehouses	-	Total floor areas for the use on the 3rd floor or higher is 200 m ² or more.	Total floor areas for the use is 1,500 m ² or more.
6	- Automobile garages - Automobile repair shops - Movie studio - Television studio	The third floor or higher is used for any of these uses.	-	Total floor areas for the use is 150 m ² or more.
7	- Storage or treatment facilities for hazardous materials of more than a specified value	-	-	All cases

(*1) Welfare facilities include:

- childrens' welfare facilities;
- maternity clinics;
- rehabilitation facilities for physically disabled persons (excluding prosthetic appliances manufacturing facilities and information centers for the visually/hearing impaired);
- social rehabilitation facilities for mentally disordered persons;
- protective institutions (excluding medical protective institutions);
- protective facilities for women;
- facilities for people with intellectual disabilities;
- welfare facilities for the elderly;
- fee charging homes for the elderly; and
- maternal and child health facilities.

(* 2) Three-story apartment houses can be of *quasi fire-resistive construction* when all of the following conditions exist:

- the area is not in a Fire Protection Zone;
- the structure has 1-hour or more *quasi fire-resistive performance*; and
- all other necessary measures are implemented from the viewpoint of fire prevention.

(3) Restrictions on buildings in *Fire-protection Zones* and *Quasi Fire-protection Zones*

Buildings in *Fire-protection Zones* or *Quasi Fire-protection Zones* must follow the requirements as shown in the following two pages.

<Exceptions> Small annexed buildings, etc. are exceptions.

If buildings are located in either *Fire-protection Zones* or *Quasi Fire-protection Zones*, openings located in *parts liable to catch fire* must be fitted with certain *fire-preventive assemblies*.

Restriction on Buildings in *Fire-protection Zone*

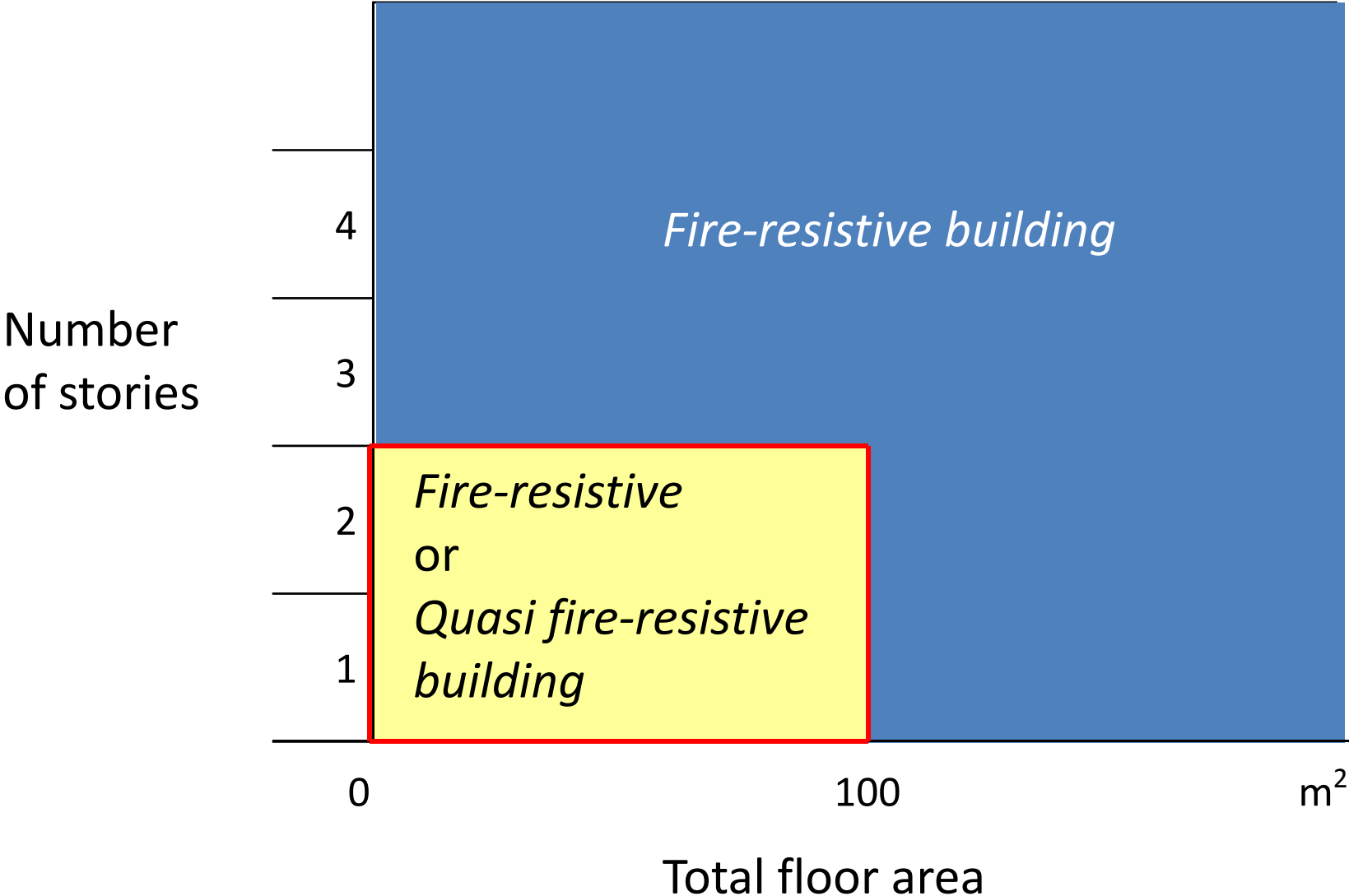

Restriction on buildings in *Quasi Fire-protection Zone*

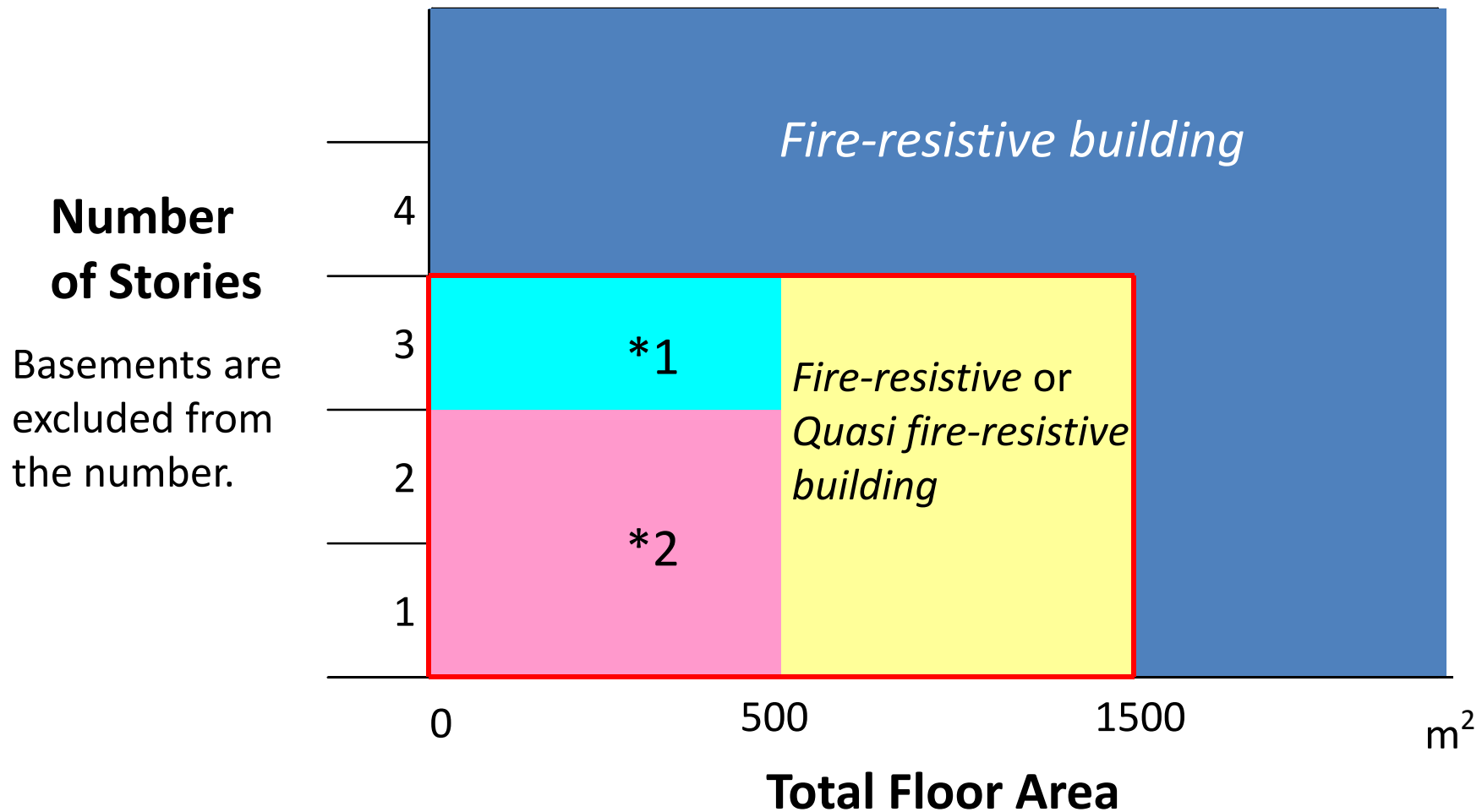

*1: *Fire-resistive building, Quasi fire-resistive building*, building stipulated in Article 136-2 of the BSL Enforcement Order

*2: *Fire preventive construction* for the external walls and soffits liable to catch the fire of wooden buildings

6-4 Fire compartment

Fire-resistive buildings, etc. must be separated into fire compartments with, but not limited to:

- (a) floors or walls of *fire-resistive construction*, etc.; and
- (b) fire doors.

These fire compartments have the following categories.

(1) Area separations

Area separations are arranged to prevent the horizontal spread of fire within a building. They have walls and floors of *fire-resistive construction*, fire doors, and so on. (see the following three pages)

In addition, wooden buildings with a floor area of more than 1,000 m² must be effectively divided with fire walls into areas of no more than 1,000 m², unless they are *fire-resistive buildings* or *quasi fire-resistive buildings*.

Buildings/parts of buildings		a. Maximum allowable floor area of each fire compartment b. Methods of separation
Buildings whose principal building parts are of <i>fire-resistive construction</i>		a. 1,500 m² (*1) b. Floors and walls: <i>1-hour quasi fire-resistive construction</i> Openings: <i>Specified fire-preventive assembly</i> (*2)
Quasi fire-resistive buildings	Voluntary <i>Quasi fire-resistive buildings</i>	a. 1,500 m² (*1) b. Floors and walls: <i>1-hour quasi fire-resistive construction</i> Openings: <i>Specified fire-preventive assembly</i> (*2)
	Obligated <i>Quasi fire-resistive buildings</i>	- Type of <i>1-hour quasi fire-resistive construction</i> - Type of NC
	- Type of <i>quasi fire-resistive construction</i> - Type of fire-resistive external walls	a. 500 m² (*1) b. Floors and walls: <i>1-hour quasi fire-resistive construction</i> Openings: <i>Specified fire-preventive assembly</i> Partition walls: Partition walls in the key locations are of <i>quasi fire-resistive construction</i> . (*3)

Remark: Each type of Quasi fire-resistive buildings are explained in 6-2.

Relaxation (*1):

- In cases where automatic fire extinguishing equipment (such as sprinklers) is provided, the maximum allowable floor area of each fire compartment can be doubled.

Exceptions (*2):

- Seating space in theaters, movie theaters, entertainment halls, grandstands, public halls, assembly halls, and space for gymnasia, factories, etc.
- Staircases, hoistways (elevator shafts) including passenger lobbies partitioned to constitute fire compartments.

Exceptions (*3):

- Space for gymnasia, factories, etc. with NC or Q-NC for interior finishes.
- Staircases or hoistways (elevator shafts) including passenger lobbies with NC or Q-NC for interior finishes partitioned to constitute fire compartments.

Area Separations for high-rise buildings

Buildings/parts of buildings		a. Maximum allowable floor area of each fire compartment (*1) b. Methods of separation
11 th floor, or higher	Interior finish and base lined with NC	a. 500 m² b. Floors and walls: <i>Fire-resistive construction</i> Openings: <i>Specified fire-preventive assembly (*2)</i>
	Interior finish and base lined with Q-NC	a. 200 m² b. Ditto (*2)
	Other than above	a. 100 m² b. Floors and walls: <i>Fire-resistive construction</i> Openings: <i>Fire-preventive assembly (*2)</i>

Relaxation (*1):

- In cases where automatic fire extinguishing equipment (such as sprinklers) is provided, the maximum allowable floor area of each fire compartment can be doubled.

Exceptions (*2):

- Staircases and hoistways (elevator shafts) including passenger lobbies, corridors or other evacuation spaces, or housing units in apartment houses not exceeding 200m², where these are partitioned to provide fire compartments.

(2) Shaft enclosures

Vertical spaces, such as staircases, hoistways (elevator shafts), pipe spaces, wellholes, etc. that pass through two stories or more, must be, in principle, separated from other spaces with:

- (a) floors or walls of *quasi fire-resistive construction*; or
- (b) *fire-preventive assemblies* as stipulated in Article 2 Item (9-2) (b) of the BSL.

(3) Mixed-use separations

In *special buildings* (see **6-3**) of complex uses, parts of different use categories must be separated from each other with:

- (a) floors or walls of *1-hour quasi fire-resistive construction*; or
- (b) *specified fire-preventive assemblies* defined in Article 112 paragraph 1 of the *Enforcement Order*.

6-5 External finishing

In order to prevent buildings from catching fire, restrictions are placed on external finishes for roofs, soffits, external walls, and openings.

(1) Fire prevention restrictions for roofs

For buildings which:

- (a) have a total floor area in excess of 1000 m² ; or
- (b) are located in certain areas (*Fire-protection Zones, Quasi Fire-protection Zones, or Zones based on Article 22*),

roofs must be made in such a way that they do not catch fire, melt, or undergo splitting, etc. from sparks caused by fires.

(2) Restrictions for external walls and soffits located in *parts liable to catch fire*

External walls and soffits of wooden buildings located in *parts liable to catch fire* must be of *fire-preventive or quasi fire-preventive construction*, for example, walls that are finished with mortar or laminated with gypsum board, in accordance with:

- the use of the building;
- the total floor area; and
- the zone in which it is located.

(see the next page)

Remarks:

If a building stands in two (or more) of the above zones, the stricter (or strictest) provisions of the restrictions in the zones are applied to the whole building.

Fire-preventive construction of parts liable to catch fire on the external walls and soffits of buildings, such as wooden buildings

Areas	Building type	Parts	Construction
In <i>Quasi Fire-protection Zones</i>	All buildings	External walls and soffits in <i>parts liable to catch fire</i>	<i>Fire-preventive construction</i>
in the <i>Areas based on Article 22 of the BSL</i>	1 Schools, theaters, movie theaters, entertainment halls, grandstands, public halls, assembly halls, markets, or public bathhouses 2 Automobile garages (only applied in cases where aggregate of floor areas for the said use exceeds 50 m ²) 3 Department stores, apartment houses, dormitories, hospitals, or warehouses (only applied in cases where the number of stories is two and the total floor area for the said use exceeds 200 m ²)	External walls and soffits in <i>parts liable to catch fire</i>	<i>Fire-preventive construction</i>
	4 Other uses	External walls in <i>parts liable to catch fire</i>	Structure satisfying <i>quasi fire-preventive performance</i>
All areas	Buildings whose total floor area (aggregate of total floor areas in case of 2 or more wooden buildings on the same site) is more than 1,000 m ²	External walls and soffits in <i>parts liable to catch fire</i>	<i>Fire-preventive construction</i>

6-6 Internal finishing

Finishing materials for ceilings and walls of the buildings are restricted in accordance with their:

- use;
- scale;
- construction types; and
- etc.

for the purpose of retarding the initial growth of fire, ensuring safe evacuation in the initial stage of fire, for instance, controlling the amount of smoke generated with the spread of fire, so as not to obstruct the way for evacuation.

The ceilings and walls of buildings subject to those restrictions must be finished, according to fire safety properties required of the part concerned, with:

- NC (noncombustible materials);
- Q-NC (quasi-noncombustible materials); or
- FR (fire retardant materials).

(see **Annex 3**)

6-7 Fire evacuation

Codes relating to the arrangement and the specification of evacuation measures such as:

- escape stairs;
- smoke exhaust equipment;
- lighting apparatus for emergency use;
- entrances for emergency use;
- elevatory equipment for emergency use;
- etc.

are provided in order to safely evacuate people to ground or to back up fire fighting and rescue.

Where evacuation safety has been verified using *Verification Method for Evacuation Safety*, etc., some *Specific Provisions* may not be applied to the building. (see **4-2(4)**)

(1) Through Stairs (Direct Stairs)

For prompt escape from upper floors or from the basement, *through stairs*, which connect directly to the evacuation floors that have exits to the ground, must be provided in such a way that the walking distance from any part of the rooms to the *through stairs* be within a certain distance.

Furthermore, large buildings or certain *special buildings* must have two or more *through stairs* for emergency, in case when one of them cannot be used. In this case, two or more stairs must be arranged as well as can be so that people can escape in different directions. (The overlap of the walking distances leading to the two or more *through stairs* must not be more than half of the length of the required walking distance.)

(2) *Escape Stairs and Special Escape Stairs*

In:

- high-rise buildings;
- buildings with basement floors; or
- buildings used by many people, such as department stores;

ordinary *through stairs* may not be enough to ensure safe evacuation. So, such buildings must have *escape stairs* or *special escape stairs* that have safer performance against fire and smoke than ordinary *through stairs*. (see the next page)

Escape Stairs (Example)

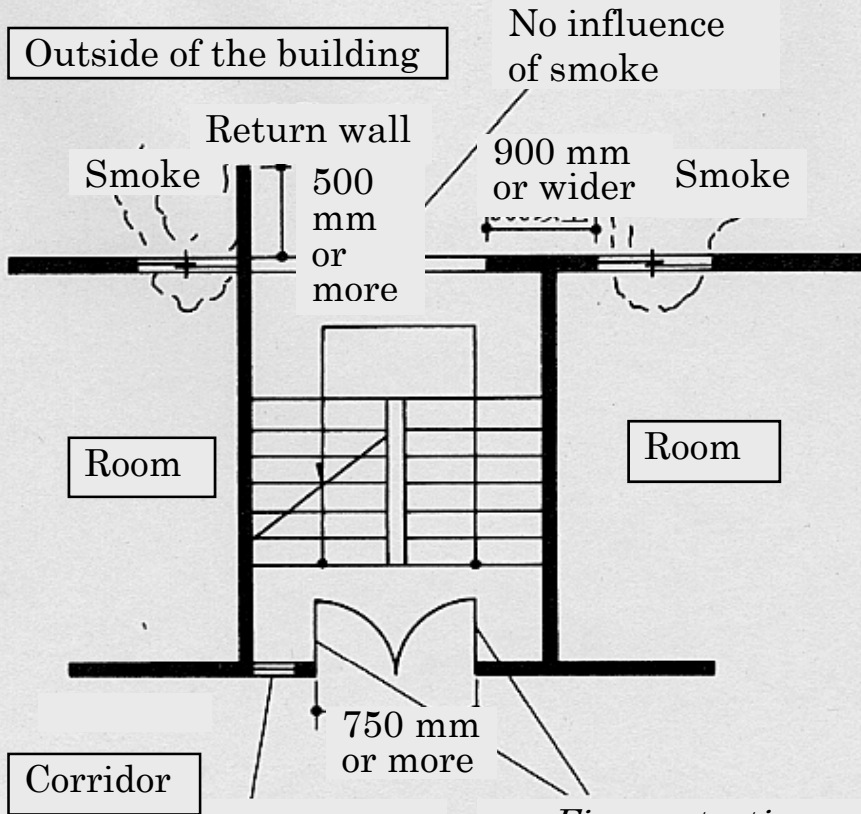

Window must be a *fire-protective assembly* having 20-minutes fire shielding performance, be fixed, and have an open area of less than 1 m².

Fire-protective assembly having 20-minutes fire

Special Escape Stairs (Example)

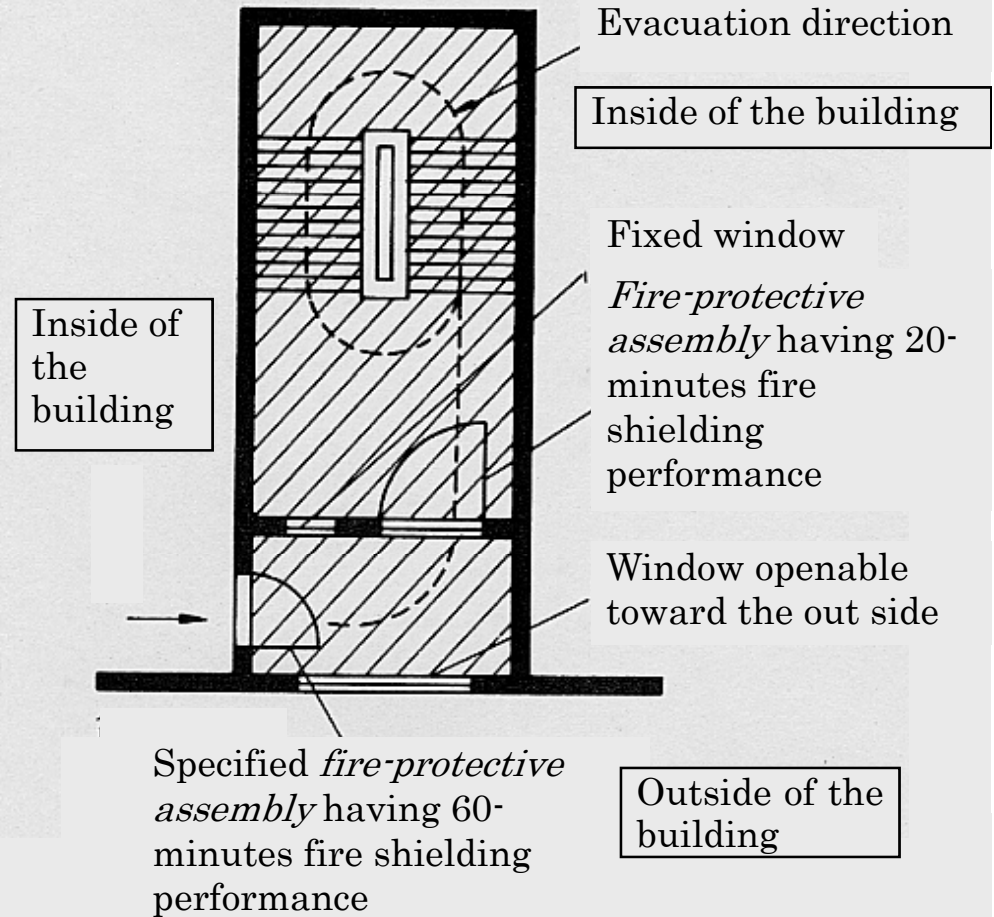

(3) Exits on the Evacuation Floor

Regarding the evacuation floors, there is a limit to the walking distance both:

- from a room to the exits; and
- from *through stairs* to the exits.

(4) Passageways within a Building-site

A passageway within the building-site must be provided from an exit to an open space, such as a roadway, park or public square. This passageway must have a width of 1.5 m or more (3 m or more, in principle, in the case of large wooden buildings).

(5) Smoke Exhaust Equipment

Smoke exhaust equipment must be provided in *special buildings* and large buildings in order to effectively eliminate smoke and gas generated from combustible materials, thus ensuring a safe evacuation.

(6) Lighting Apparatus for Emergency Use

Lighting apparatus for emergency use must be provided according to the size of buildings, in order to ensure safe evacuation during a power failure.

(7) Elevatory Equipment for Emergency Use and Entrances for Emergency Use

Buildings with a height exceeding 31 m must, in principle, have elevatory equipment for emergency use for fire fighters. Also buildings must be provided with emergency entrances (elevator equipment, a balcony, or a window through which fire fighters can enter the building) on every floor, beginning with the third floor, up to 31 m in height, so that rescue work and fire fighting activities can be carried out smoothly.

Contents

Chapter 7 Building Codes for Other Fields

7-1 Building sites

7-2 Environmental sanitation

7-3 Structure of stairway

7-4 Building equipment

7-5 Structures and amusement facilities

7-1 Building sites

(1) Ground level

Ground level of a building site must be higher than the border of adjacent roads and adjacent land lots, in principle.

(2) Improvement of ground

Fills, an improvement of ground or other measures necessary for sanitation or safety must be taken if necessary.

(3) Drainage

Sites of buildings must have proper sewer pipelines, sewer channels, manholes and other facilities for the purpose of draining and disposing of rainwater and wastewater.

(4) Countermeasures against landslides

If buildings are likely to be damaged by landslides, etc., construction of retaining walls or other appropriate measures for safety must be taken.

7-2 Environmental sanitation

(1) Natural Lighting of Habitable Rooms

A habitable room is a space that is continuously used for living, working, meetings, amusement, and so on, and that includes a living room or bedroom in a house, an office room, a meeting room, a theater auditorium, a hall, etc.

Requirements for natural lighting are prescribed from the viewpoint of environmental sanitation. The following habitable rooms must, in principle, have windows and other openings for natural lighting, and the ratio of the effective area thereof to the floor area must be more than a specified ratio for, but not limited to, the following spaces:

- habitable rooms in houses;
- classrooms in schools;
- wards in hospitals or clinics;
- guestrooms in boarding houses; and
- sleeping areas in dormitories.

Calculation of “effective natural lighting”

- (a) Opening section area in habitable room x Lighting correction factor
- (b) Floor area of habitable room x 1/7 **(1/7: In case of a residence)**
- (c) Confirmation of $(1) \geq (2)$

lighting correction factor

A lighting correction factor is determined by the height of the opening section and the distance from the border with the neighboring land, etc. The figure increases if the opening section is higher or the border is farther.

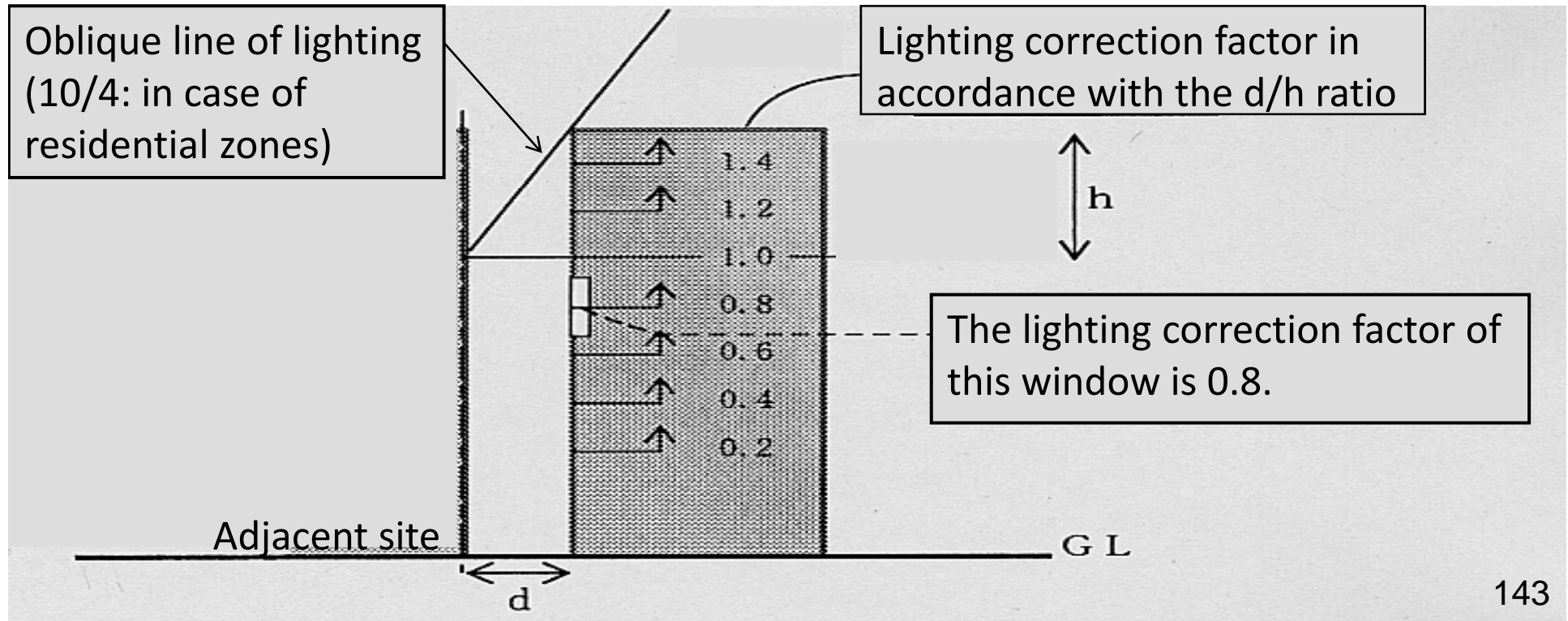

(2) Ventilation of Habitable Rooms

Ventilation equipment must be installed in:

- habitable rooms in theaters and movie theaters; and
- rooms having equipment that uses a flame, such as kitchens, bathrooms, etc.

There is another requirement of installation of mechanical ventilation equipment for habitable rooms as a countermeasure against chlorpyrifos emitted from furniture, etc. (see **(3)**)

(3) Countermeasures against Sick Building Issue

There are some requirements in order to prevent harm to human health by the scattering of asbestos or by emissions of other harmful substances from buildings materials.

(a) It is prohibited to add asbestos to building materials.

(b) It is prohibited to use the following building materials:

- sprayed asbestos; and
- sprayed rock wool that contains more than 1 % in weight of asbestos;

excluding those approved by the Minister as those do not cause the scattering or emission of asbestos particles.

(c) In a building with habitable rooms,

- It is prohibited to use building materials that might emit chlorpyrifos, an insecticide for termites;
- It is restricted to use of building materials that might emit formaldehyde; and
- It is required to install mechanical ventilation equipment, except in traditional wooden houses that have lower air tightness.

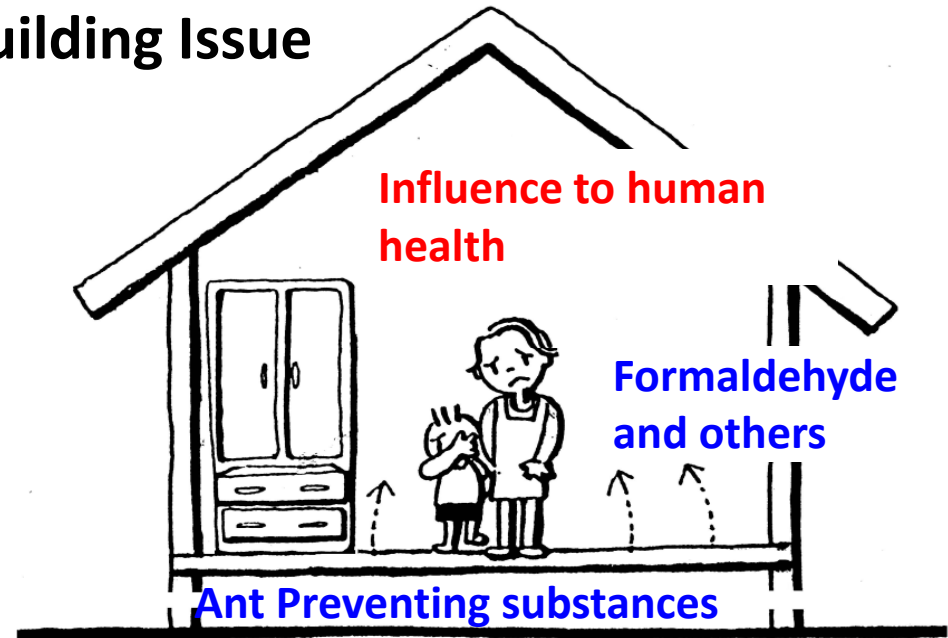

(4) Others

The following regulations are also provided with respect to the environmental sanitation and safety in the daily use of buildings.

(a) Height of the ceilings of habitable rooms

The height of the ceilings of habitable rooms must be 2.1 m or more (on average in each room).

(b) Height of floors from the ground and methods of damp proofing in habitable rooms

In principle, the first floor of wooden buildings must be 45 cm high, from the ground, or more, and must be provided with ventilation under the floor.

(c) Sound blocking of the separation walls

Separation walls between each unit of row houses or apartment houses must be of a structure that has effective sound insulation.

7-3 Structure of stairway

Some regulations are provided for stairs and for slope-ways (*) from the viewpoint of ensuring safety in daily situations.

(*) If a slope-way is provided as an additional exit route, and therefore not required in the BSL, these regulations are not applied to such slope-ways.

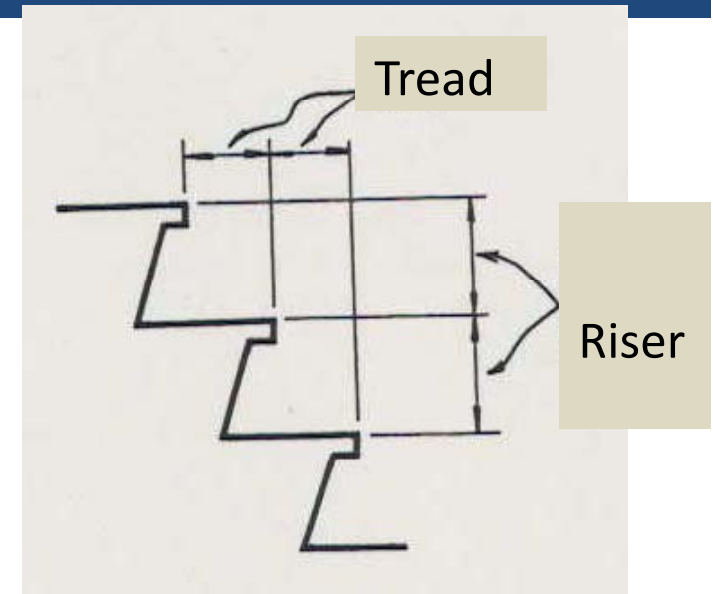

(1) Size of width, riser and tread of stairway

Type of stairway	Width of stairway and landing	Riser	Tread
Stairway for children in elementary school	≥ 140 cm	≤ 16 cm	≥ 26 cm
Stairway in junior high school, high school, store, theatre, movie theatre or other public facilities	≥ 140 cm	≤ 18 cm	≥ 26 cm
Stairway in residence (excluding public space in housing complex)	≥ 75 cm	≤ 23 cm	≥ 15 cm

(2) Handrails

A stairway is required to have handrails. In case either side of stairway and landing has no handrail, it is required to install a side wall.

(3) Landings

Concerning stairway in elementary, junior high or high school, department store, theatre, etc. it is required to build a landing for every 3m height or less in case the height of the stairway exceeds 3m. For other cases, it is required to build a landing for every 4m height or less.

(4) Slope-ways

The slope of slope-ways in place of stairs must not exceed $1/8$.

(1) Sewage

- (a) In regions where wastewater can be treated at a final disposal plant, it is required to have flush toilet for which sewage pipes are directly connected to the sewage system.
- (b) In case of discharging waste from toilet to other than the sewage system, it is required to install **a septic tank**. In areas other than districts planned for sewage treatment, it must be **a combined septic tank (a combined kitchen waste and toilet sewage treatment tank)** as per the Purification Tank Act.

(2) Plumbing Facilities (Water Supply and Drainage)

(a) Sanitary criteria for plumbing facilities

- Not to directly connect plumbing facilities for drinking water and other plumbing facilities.
- To install drain traps, etc. For plumbing facilities for drainage.

(b) Criteria for plumbing facilities in general (It is necessary to design plumbing facilities considering different aspects such as structure, fire prevention and hygiene.)

- To avoid a piercing arrangement that would cause a problem in the aspect of structural load-bearing capacity.
- To take countermeasure against corrosion according to the material in case there is a risk of corrosion, such as being buried in concrete.
- To use incombustible materials for duct, dust chute, etc. in case of being installed in a three-story or higher building.

(3) Elevatory equipment

Elevatory equipment must be constructed for safe operation. In addition, hoistways must not become channels for the spread of fire.

Elevatory equipment installed in buildings is classified into the following:

(a) **Elevators:** elevatory equipment (*) that:

- transports people;
- transports people and articles; or
- transports articles, whose cage has a horizontally projected area exceeding 1 m², and whose ceiling height exceeds 1.2 m.

(*) excluding escalators

(b) **Escalators**

(c) **Elevatory equipment exclusively for small objects:** elevatory equipment used to transport articles, and whose cage has a horizontally projected area of 1 m² or less, and whose ceiling height is not more than 1.2 m.

The requirements for each items are as shown in the next page.

For special elevators, such as elevators in a dwelling, some requirements are replaced by the Ministerial notification.

(a) Elevators

Cages and principal structural parts of elevators (parts to support or suspend cages) must either:

- meet the construction methods specified by the Minister; or
- have their safety confirmed through the **elevator strength verification method**;
or
- be constructed by a construction method approved by the Minister.

Requirements on other parts, such as drive units, machine rooms, and safety devices, are also provided.

(b) Escalators

The slope must be no more than 30 degree. The width of the steps must be no more than 1.1 m. Steps and principal structural parts of escalators (parts to support or suspend steps) must either:

- meet the construction methods specified by the Minister; or
- have their safety confirmed through the **escalator strength verification method**; or
- be constructed by a construction method approved by the Minister.

Requirements on other parts, such as drive units, trapping prevention systems, and handrail structures, are also provided.

(c) Elevatory equipment exclusively for small objects

The regulations for elevators are partially applied, as necessary.

7-5 Structures and amusement facilities

The BSL applies to:

(1) Structures, such as:

- (a) chimneys exceeding 6 m in height (including any supporting frame or stay wire, but excluding stove chimneys);
- (b) advertisement towers, advertisement billboards, decorative towers, and memorial towers exceeding 4 m in height;
- (c) elevated water tanks, silos, and observation towers exceeding 8 m in height; and
- (d) retaining walls exceeding 2 m in height.

(2) Amusement Facilities, such as:

- (a) elevated amusement facilities such as water chutes, and roller coasters; and
- (b) rotating amusement facilities that use motors such as merry-go-rounds, Ferris wheels, octopus rides, and aero-towers.

The BSL and its related documents provide requirements for the abovementioned in order to secure safety.

Contents

Chapter 8 Zoning Codes

8-1 *City Planning Law* and Zoning Codes

8-2 Land use

8-3 FAR (Floor area ratio) and BCR (Building coverage ratio)

8-4 Building site and roads

8-5 Building height

8-6 Special exceptions relating to bulk/height control of buildings

8-7 Other regulations of Zoning Codes

(1) City Planning Law

The City Planning Law provides for:

- (a) The items to be determined by city planning;
- (b) The procedure for deciding them;
- (c) Restrictions concerning city planning; and
- (d) City Planning projects.

The aim is to realize the sound development and systematic improvement of cities.

Each city planning is determined by a local government under the consultation of the city planning committee of the local government.

The items determined by city planning are classified into three categories, as shown in the next page. Zoning codes stipulated in the BSL are related to the city planning based on the City Planning Law.

Relationship between the City Planning Law and the BSL

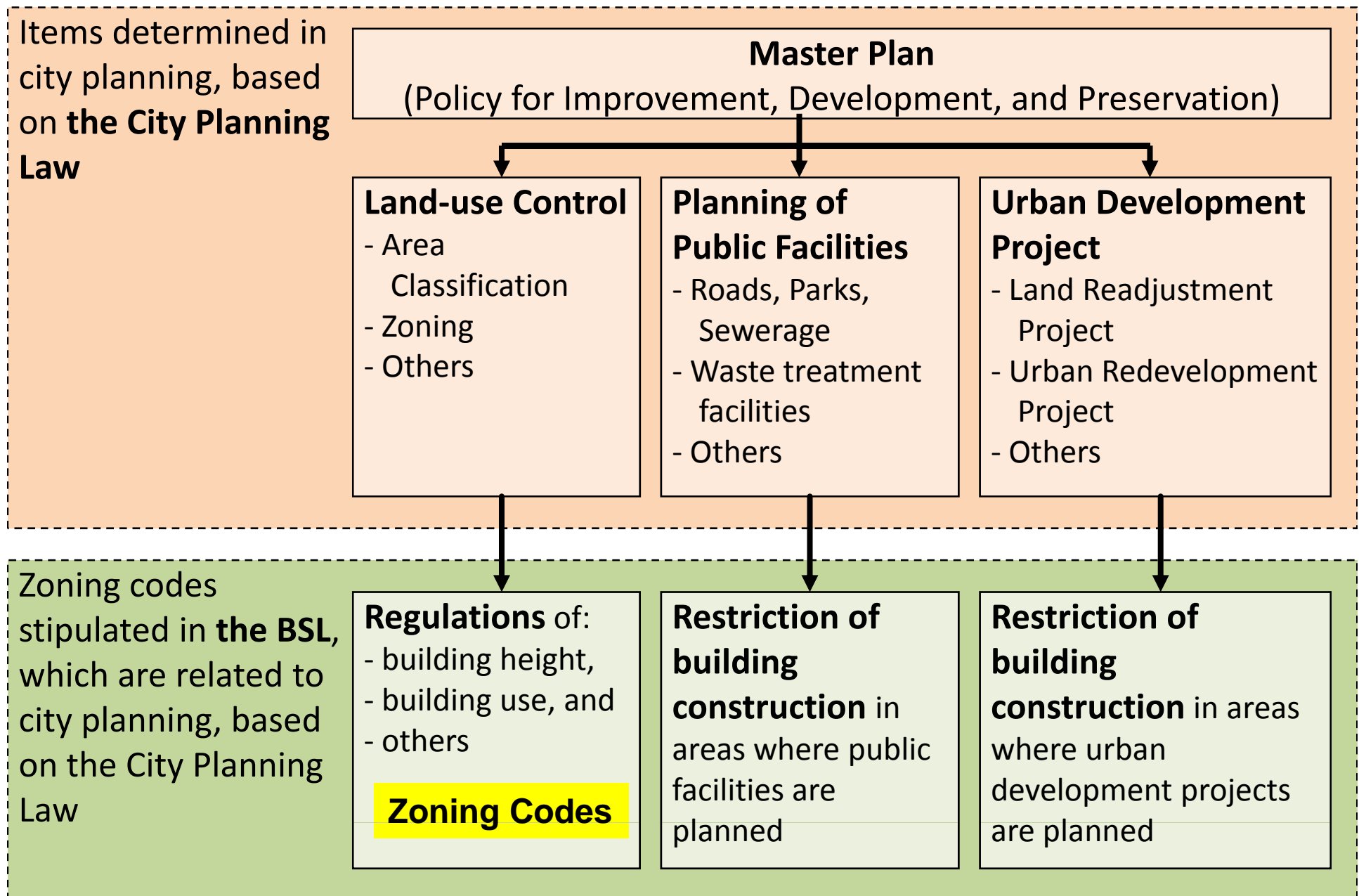

(2) City Planning Area

The zoning codes are intended to ensure the orderly arrangement of buildings as a group, in order to maintain a good urban environment. In principle, they are applicable only to:

- *City Planning Areas* (areas designated as city zones under the City Planning Law);
and
- *Quasi City-Planning Areas* (areas other than *city-planning areas*, where future urban improvement and development and utilization could be put at risk if there are no restriction on land use).

City Planning Areas in major cities are divided into:

- *Urbanization Promotion Area*, where urbanization is strictly controlled; and
- *Urbanization Control Area*, where is already urbanized, or where urbanization is promoted.

Concept of City Planning Area

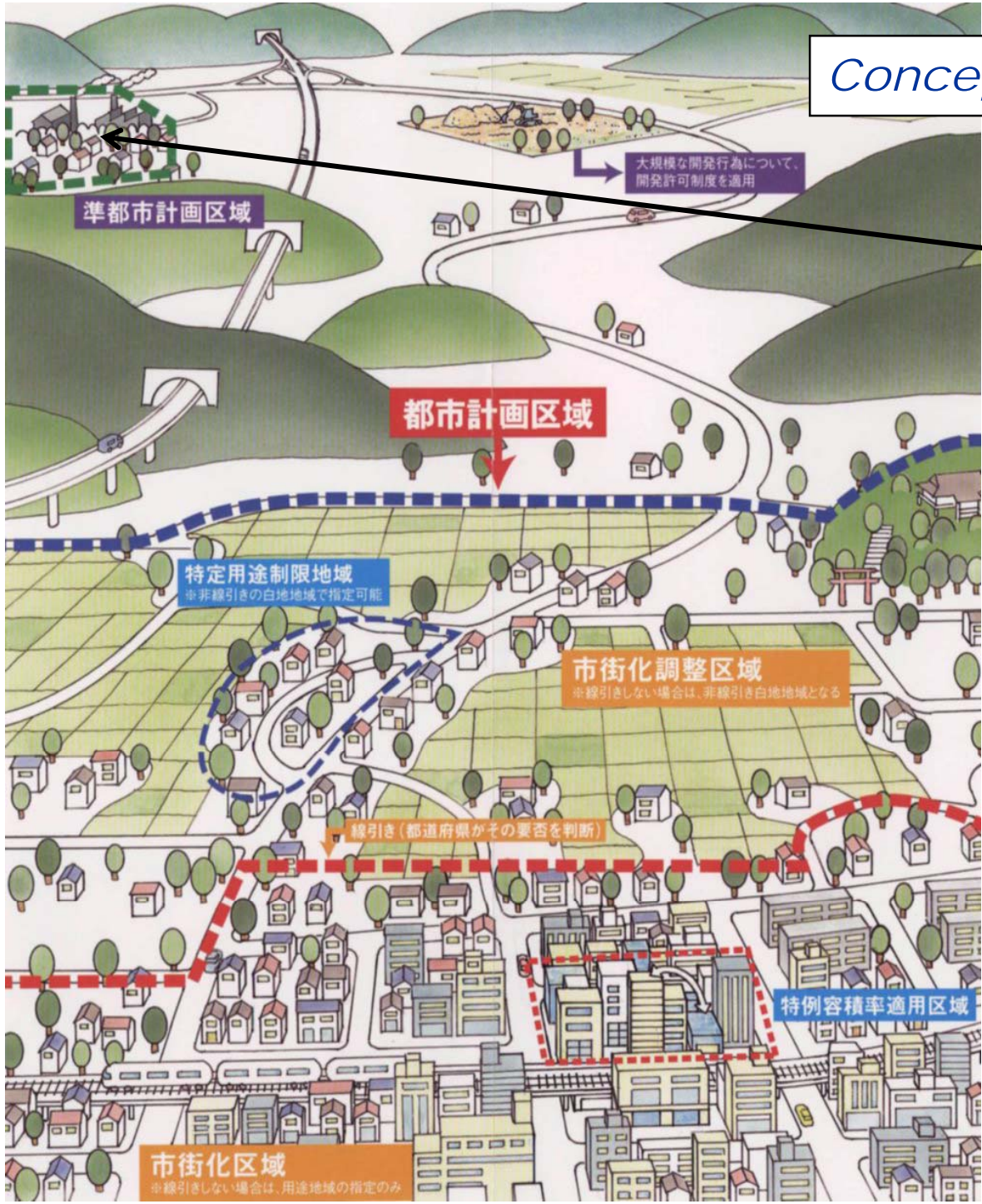

Quasi City Planning Area

Urbanization Control Area

City Planning Area

Urbanization Promotion Area

8-2 Land use

From the viewpoint of urban environment and also for the purpose of preventing the proximity of buildings that differ widely in their use:











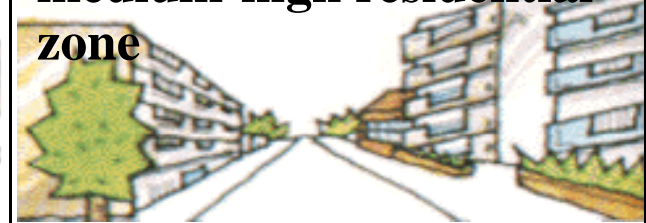

- (a) there are 12 types of land-use zones are designated by the local governments in their respective administrative areas, based on the City Planning Law; and
- (b) the use of buildings is restricted by the BSL according to land-use zones.**

12 types of land-use zones and their purposes of are shown in the next page. For example, in a zone that is defined as a Residential Zone, the construction of factories and other facilities that would lead to the deterioration of the living environment is restricted, while the construction of schools and hospitals is restricted in areas that are designated as Industrial Zones.

Land-use Zones and their purposes

Zones	Purposes
<i>Category I Exclusively Low-rise Residential Zone</i>	to ensure an excellent living environment for low-rise houses.
<i>Category II Exclusively Low-rise Residential Zone</i>	to ensure an excellent living environment primarily for low-rise houses
<i>Category I Mid/high-rise-oriented Residential Zone</i>	to ensure an excellent living environment for mid/high-rise houses
<i>Category II Mid/high-rise-oriented Residential Zone</i>	to ensure an excellent living environment primarily for mid/high-rise houses
<i>Category I Residential Zone</i>	to ensure a living environment for houses
<i>Category II Residential Zone</i>	to ensure a living environment primarily for houses
<i>Quasi-residential Zone</i>	for the promotion of businesses suited to the characteristics of the neighborhood that are adjacent to roads, while at the same time preserving an excellent living environment
<i>Neighborhood-Commercial Zone</i>	for the promotion of convenience for conducting commercial and other kinds of business to supply daily necessities to the inhabitants of nearby residential areas.
<i>Commercial Zone</i>	primarily for the promotion of convenience for commercial and other kinds of business
<i>Quasi-industrial Zone</i>	primarily for the promotion of convenience for industries which are not likely to damage the environment
<i>Industrial Zone</i>	primarily for the promotion of convenience for industries
<i>Exclusive Industrial Zone</i>	for the promotion of convenience for industries

Image of Land-use Zones

<p>Category I exclusively low-story residential zone</p> 	<p>Category II exclusively low-story residential zone</p> 	<p>Category I exclusively medium-high residential zone</p> 
<p>Category II exclusively medium-high residential zone</p> 	<p>Category I residential zone</p> 	<p>Category II residential zone</p> 
<p>Quasi-residential zone</p> 	<p>Neighborhood commercial zone</p> 	<p>Commercial zone</p> 
<p>Quasi-industrial zone</p> 	<p>Industrial zone</p> 	<p>Exclusively industrial zone</p> 

Map of Land-use Zones (Example)

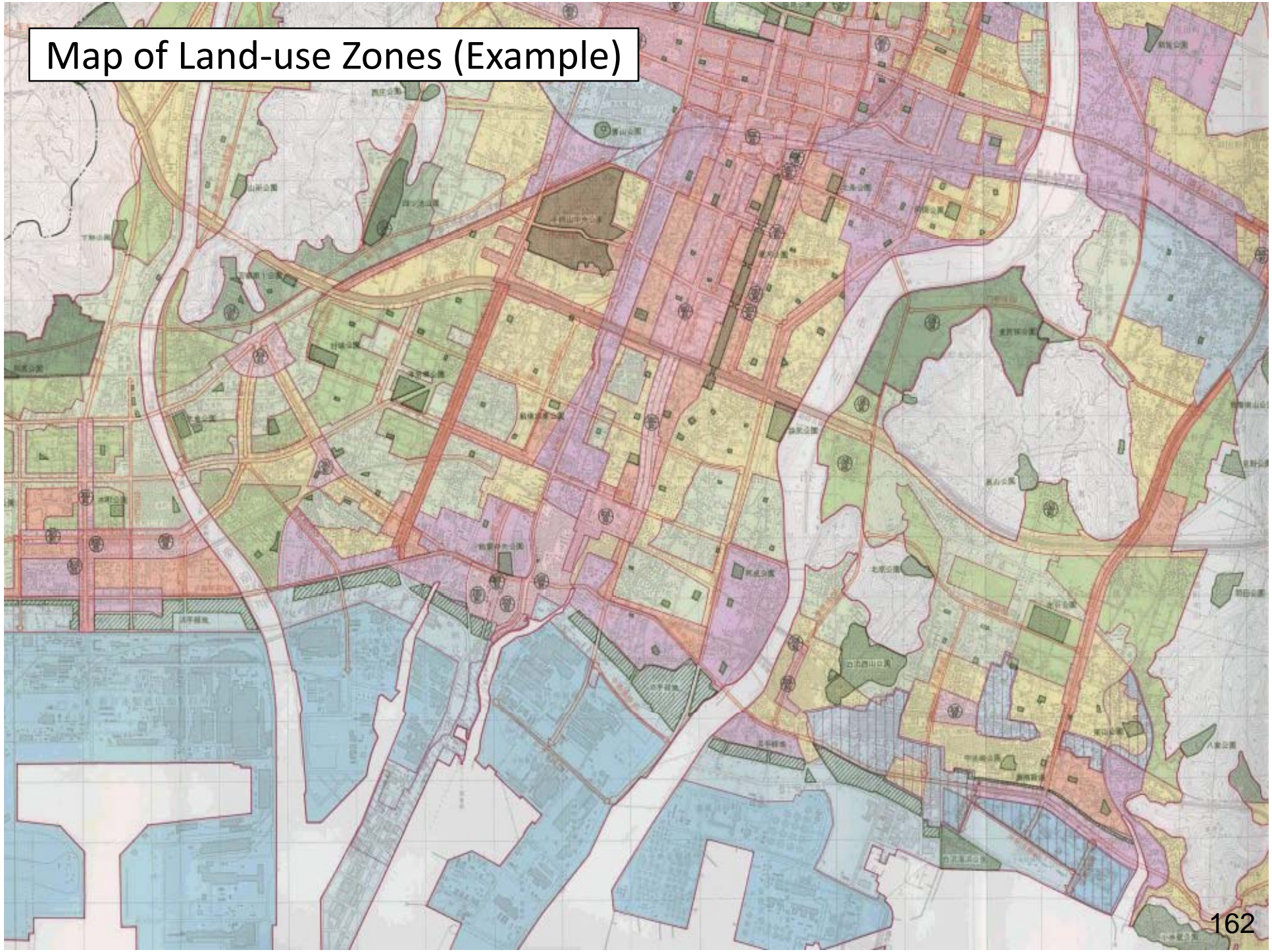

Control of Building Use by Land-use Zones

Examples of buildings	Land-use Zones											
	1 Low.Res. Z.	2 Low.Res. Z.	1 Med.Res. Z.	2 Med.Res. Z.	1Res. Z.	2Res. Z.	QuasiRes. Z.	Neigh.Com. Z.	Com. Z.	QuasiInd. Z.	Ind. Z.	Ex.Ind. Z.
Houses												×
Schools											×	×
Shrine, Church, Clinic												
Hospital, University	×	×									×	×
Store (150m ² Max.)	×											△
Store (500m ² Max.)	×	×										△
Office, Store, etc.	×	×	×	△	△							
Hotel	×	×	×	×	△						×	×
Karaoke box	×	×	×	×	×							
Independent garage	×	×										
Warehouse	×	×	×	×	×	×						
Theater	×	×	×	×	×	×	△	△			×	×
Auto repair shop	×	×	×	×	×	×	△	△				
Factory with some possibility of danger or environmental degradation	×	×	×	×	×	×	×	×	×			
Factory with strong possibility of danger or environmental degradation	×	×	×	×	×	×	×	×	×	×		



Can be built



Usually cannot be built



Can be built under some conditions

8-3 FAR (Floor area ratio) and BCR (Building coverage ratio)

FAR (Floor area ratio) and **BCR** (Building coverage ratio) of each building are calculated by the formulas below:

$$\text{FAR (\%)} = \frac{\text{total floor area ((b)+(c))}}{\text{site area(A)}} \times 100$$

$$\text{BCR (\%)} = \frac{\text{building area (b)}}{\text{site area (A)}} \times 100$$

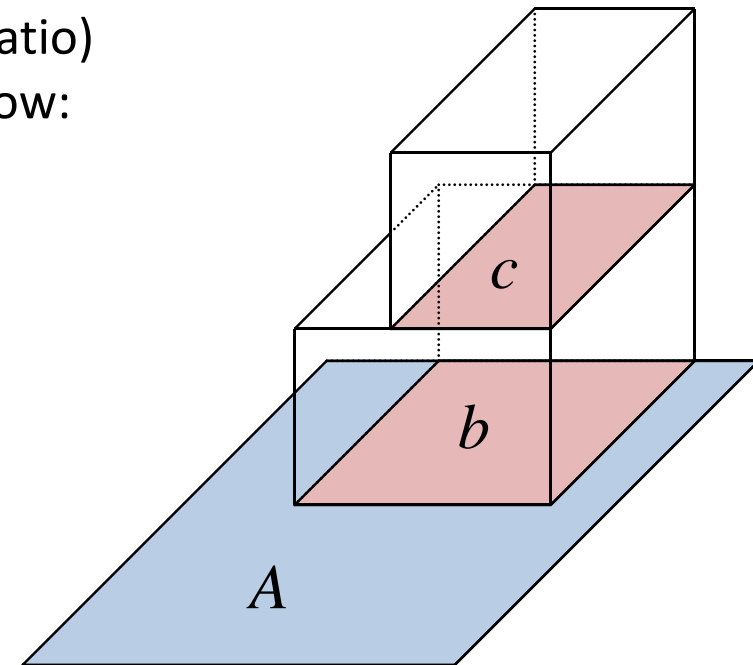

FAR and **BCR** of buildings must be less than allowable values determined by the local governments.

- (a) Allowable FAR and allowable BCR are determined by each city planning commission in accordance with the situation of the respective regions. Their values are, in principle, chosen from “the available values of allowable FAR and BCR” which are stipulated in the BSL, as shown in the next page. (Allowable FAR and BCR in areas, where land-use zones are not designated, are determined by the Designated Administrative Agencies instead of city planning commissions.)
- (b) Allowable FAR is reduced in case where the front road of the site is narrow.

Available values of allowable FAR and BCR by Land-use Zones

Land-use Zones		Available values of allowable FAR (%)	Available values of allowable BCR (%)
1	Category I exclusively low-story residential zone	50,60,80,100,150,200	30,40,50,60
2	Category II exclusively low-story residential zone	50,60,80,100,150,200	30,40,50,60
3	Category I exclusively medium-high residential zone	100,150,200,300,400,500	30,40,50,60
4	Category II exclusively medium-high residential zone	100,150,200,300,400,500	30,40,50,60
5	Category I residential zone	100,150,200,300,400,500	50,60,80
6	Category I residential zone	100,150,200,300,400,500	50,60,80
7	Quasi-residential zone	100,150,200,300,400,500	50,60,80
8	Neighborhood commercial zone	100,150,200,300,400,500	60,80
9	Commercial zone	200,300,400···1300	80
10	Quasi-industrial zone	100,150,200,300,400,500	50,60,80
11	Industrial zone	100,150,200,300,400	50,60
12	Exclusively industrial zone	100,150,200,300,400	30,40,50,60
Areas where land-use zones are not designated		50, 80, 100,200,300,400	30,40,50,60, 70

8-4 Building site and roads

(1) Road Access Obligation

The boundary of any building site must, in principle, abut a road for a distance of at least 2 m. (See definition of “Roads” of (3).)

<Exception>

- (i) Roads exclusively used for automobile traffic, and
- (ii) The roads having no access of automobiles to the roadside, such as elevated roads, are not included in the roads to fulfill this obligation.

(2) Restrictions on In-road Buildings

No building or retaining wall may, in principle, be constructed on a road, or in such a way as to protrude onto a road. (See definition of “Roads” of (3).)

<Exception>

Buildings, which are necessary for the public interest, such as public lavatories and police boxes, are allowed to be constructed on the roads if they are permitted by the Designated Administrative Agency.

Road Access Obligation

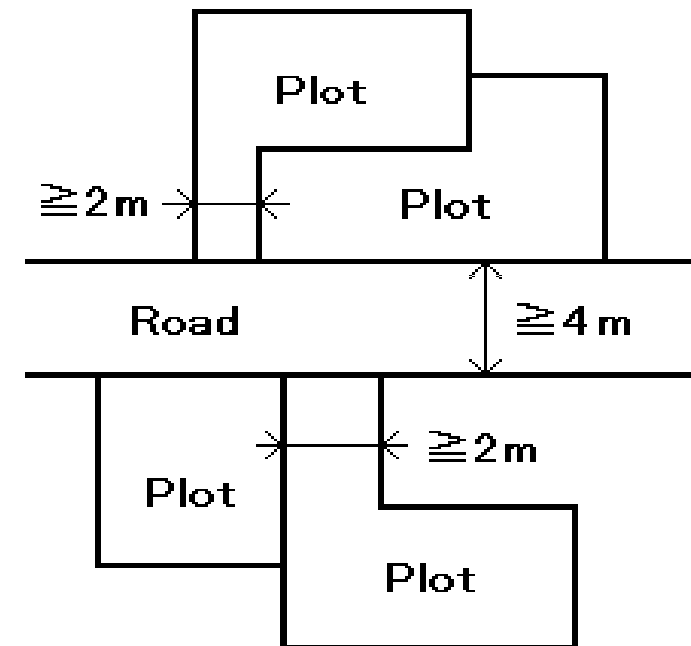

(1) Definition of “Roads” in BSL

“Roads” in the Zoning Codes mean the roadways as shown in the table below.
(excluding underground roadways)

Construction Width	Construction of the road was before the time of the application (*1).	Construction of the road is after the time of the application (*1)
4 m or more (*2)	All roadways , including privately-operated roadways, are “Roads”.	<ul style="list-style-type: none"> - In case of publicly-operated roadways, such as those based on the Road Law, all roadways are “Roads”. - In case of privately-operated roads, roadways which were constructed in compliance with required standards, and certified through the related laws, such as City Planning Law and BSL.
Less than 4 m (*2)	Roadways designated by the DAA (*3) are “Roads”. (See the next page)	No roadways are adopted as “Roads”.

(*1) “The time of the application” means the time when the area was designated as City Planning Areas or Quasi-city Planning Area.

(*2) 6 m instead of 4m, in areas where the DAA (*3) designated as such.

(*3) DAA means Designated Administrative Agency.

Narrow roadways designated by DAA as “roads”

Definition

A roadway:

- (a) next to which buildings actually stood at the time of the application of Zoning Codes;
- (b) of which width was less than 4 m at that time; and
- (c) which is designated by a Designated Administrative Agency, is regarded as a “road”.

Boundaries in ordinary cases

Lines 2 m in horizontal distance from the center line are regarded as the boundary lines of the “road”. (See the right figure) No buildings may not be built in the total width of 4 m.

Boundaries in special cases

If the roadway is along a cliff, stream, railway site or the like within 2 m in horizontal distance from the center line,

- (a) the boundary line of the side abutting on the cliff, etc.; and
 - (b) a line on the opposite side of the roadway, 4 m in horizontal distance from the boundary line of (a),
- are regarded as the boundary lines of the “road”, notwithstanding the preceding paragraph. (See the next page)

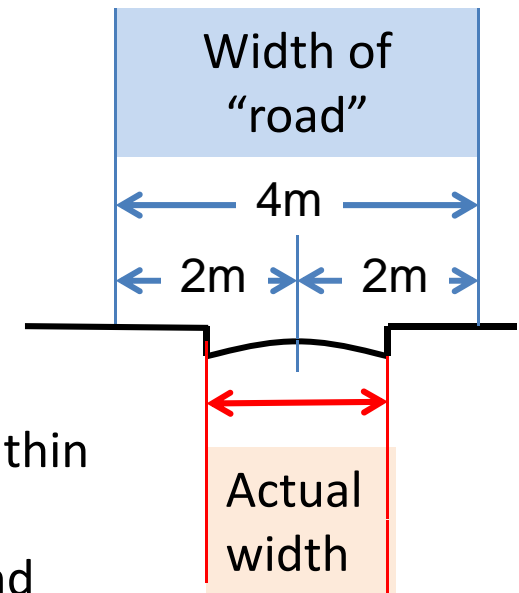

Widening of narrow roadways designated by DAA

No building may not be built in the width of 4 m.

4 m width of "road"

Actual width at the time of the application of the Zoning Codes

Condition at the time of the application of the Zoning Codes

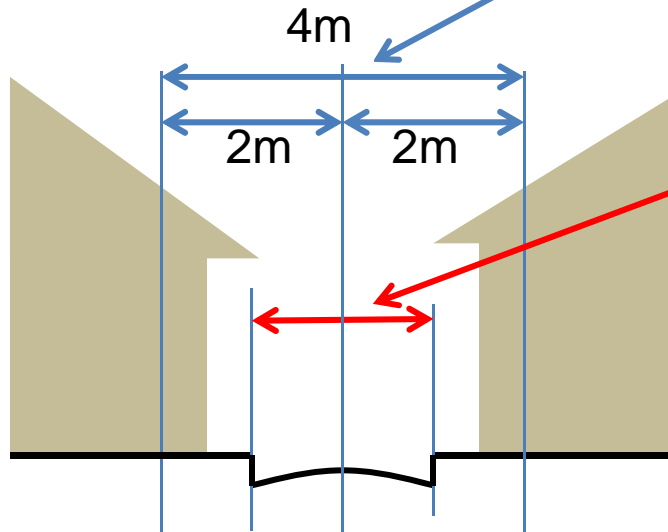

Ordinary cases

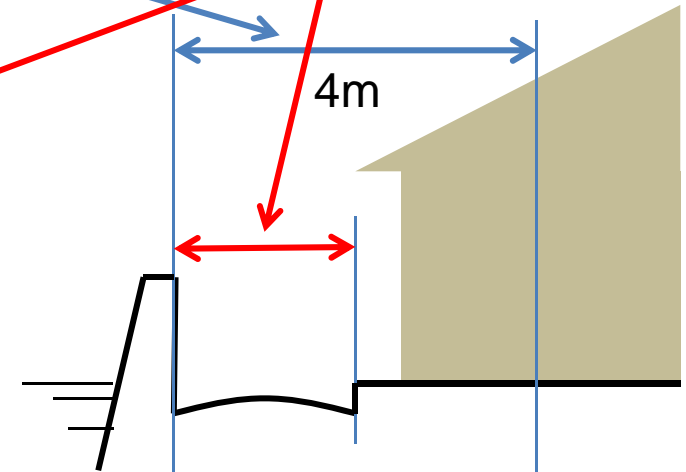

Special cases

Future condition

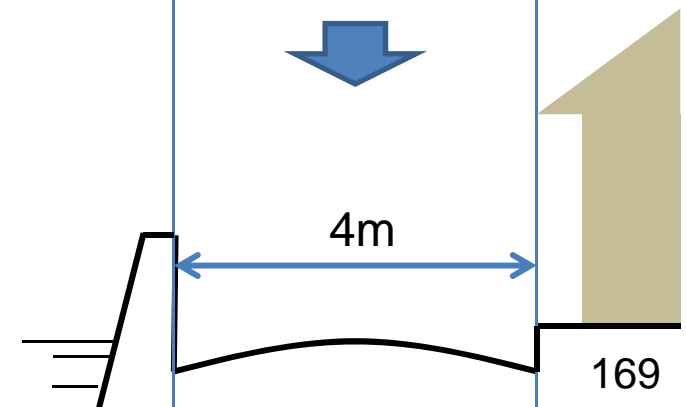
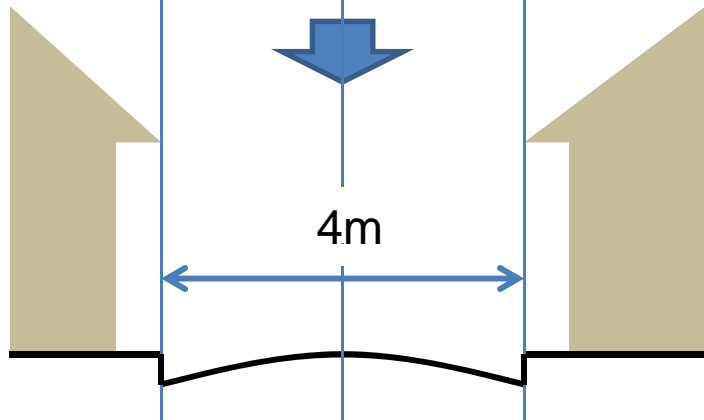

8-5 Building height

(1) Building height restrictions in *Category I/Category II Exclusively*

Low-rise Residential Zones

Category I and Category II Exclusively Low-rise Residential Zones are specified so that an excellent living environment for low-rise residences is maintained. In these regions, it is prohibited, in principle, to build a building whose height exceeds 10 m or 12 m, whichever is specified under city planning.

(2) Slant Plane Restrictions (allowable building height in proportion to the distance from the boundary)

These restrictions are designated to limit the height of buildings according to:

- (a) the distance from each part of the building to the opposite side of the road that it faces (the slant planes from the roads); and
- (b) the distance from each part of the building to the adjacent site boundaries (the slant planes from adjacent sites); and
- (c) the distance from each part of the building to the north boundary of the site (the slant planes from the north-facing adjacent sites).

This is to ensure that there is enough unobstructed space for light and ventilation between buildings and on streets. The degree of application of these slant plane restrictions differs according to each land-use zone. (see the next page)

Image of Slant Plane Restrictions

(In the case of residential land use area)

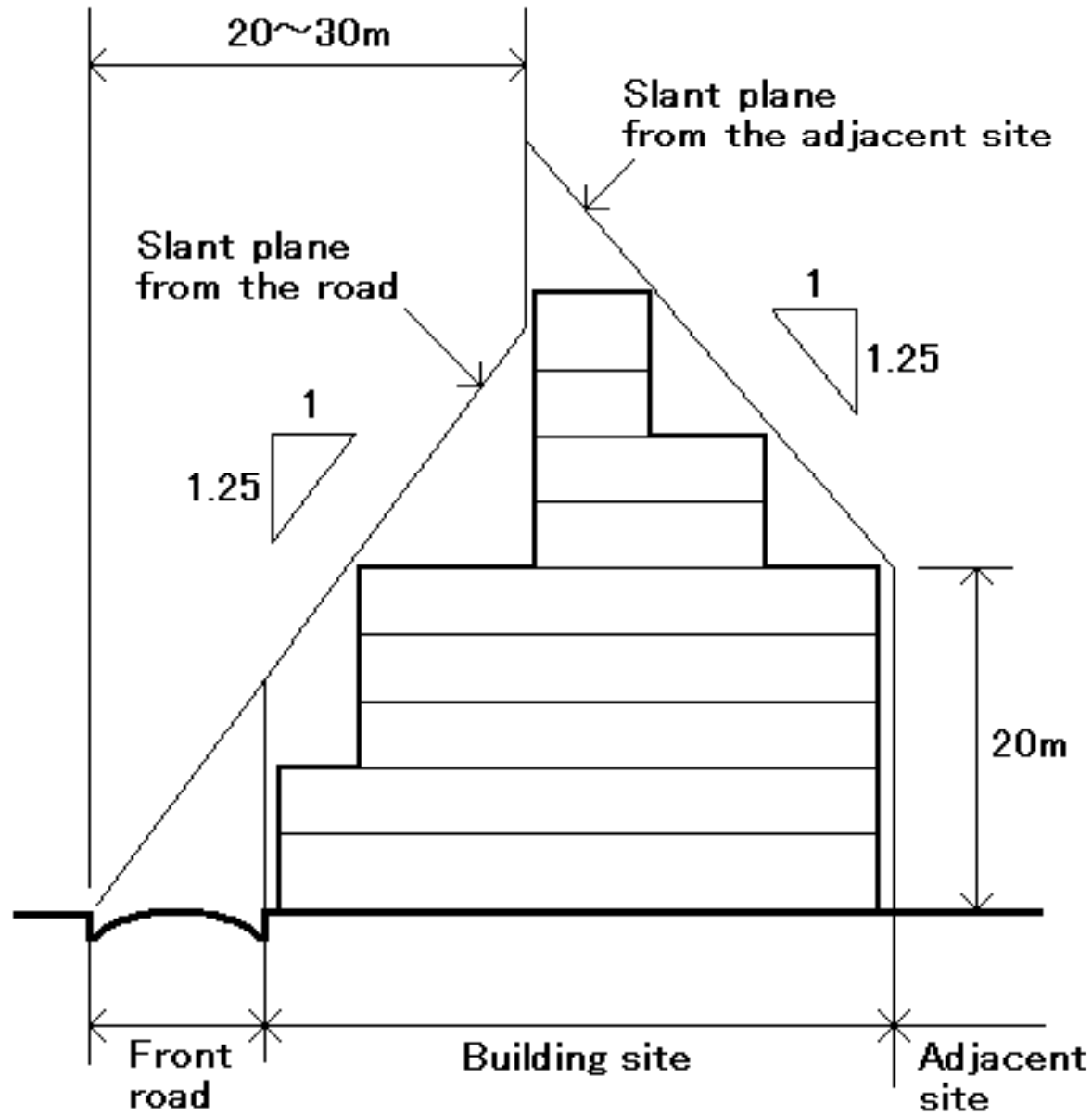

(3) Shadow Restriction

Shadow restriction aims, in principle, to limit the height of buildings so as to ensure sufficient sunlight in residential zones. The local governments may designate areas (*1) where this restriction applies, and *allowable hours of shadows* (*2) for each designated areas.

(*1) The following land-use zones can be designated:

- *Category I and II Exclusively Low-rise Residential Zones;*
- *Category I and II Mid/high-rise-oriented Residential Zones;*
- *Category I and II Residential Zones;*
- *Quasi-residential Zones;*
- *Neighborhood-Commercial Zones;*
- *Quasi-industrial Zones;*
- Areas where no land-use zones are designated.

(*2) *Allowable hours of shadows* means a period of hours per day in which buildings may cast shadows outside of their respective areas.

8-6 Special exceptions relating to bulk/height control of buildings

Fundamental restrictions relating to the bulk (FAR and BCR) and height of buildings have been briefly described above, but there are also various exceptions to those restrictions. The following are special restrictions aligned with the purpose of city planning:

- (1) **Height Control Districts** (designated in city planning as districts where the minimum and/or maximum height of buildings is stipulated);
- (2) ***Specified Blocks*** (where construction is implemented in a specified block in a city according to city planning with alleviated FAR);
- (3) ***Special District for Urban Renaissance*** (where urban renaissance is promoted according to city planning with alleviated FAR, etc.);
- (4) ***System for Integral Design*** (when building sites are of a certain size, including sufficient open space, one can receive a special exemption from FAR and the restrictions on slant planes, etc. if the *Special Administrative Agency* recognizes that construction of the building will contribute to the improvement of the city environment); and
- (5) **Others.**

8-7 Other regulations of Zoning Codes

(1) Building lot size

In an effort to discourage the development of small-scale projects that involve the subdivision of an existing single lot, the respective city planning may stipulate the minimum allowable building lot size up to 200 m², in order to ensure an excellent living environment

(2) Wall alignment

In cases where the Designated Administrative Agency designates wall alignment, Walls and columns of buildings, and gates or fences exceeding 2 m in height must not be erected beyond wall alignment.

(3) Fire resistance in *Fire Protection Zones*

See 6-3 (2) .

Although these requirements are a part of zoning codes, they are explained in in 6-3 (2) for better understanding.

(4) *District Plan*

In cases where a *District Plan* is in force as a part of city planning for the purpose of providing and protecting a favorable city-area environment that is suitable to the characteristics of the area, a city, town, or village can enact bye-laws to determine restrictions relating to matters that are particularly important concerning the site, use, construction, and equipment of buildings, as specified in the content of the District Plan.

(5) *Building Agreements*

In the interest of maintaining and further promoting a favorable living environment in residential areas and convenience in commercial areas, the BSL permits high-level standards exceeding the requirements of the general standards relating to buildings, to be determined by agreement (*Building Agreements*) among the residents of the area. These building agreements determine standards relating to the building site, position, construction, use, form, design and/or equipment by mutual consent of all landowners, etc. Such agreements come into effect through approval by the Designated Administrative Agency.

(6) Comprehensive Design Systems for Estates

Where an integrated design is used for multiple buildings on an area of land within a single estate (*Comprehensive Design Systems for Estates*), or where multiple buildings are designed to harmonize with existing buildings (design systems for continuous buildings), multiple buildings with coordinated plans will be subject to uniform road access obligation (**8-4 (1)**), FAR, slant lines, etc., within the same site.

Contents

Chapter 9 Seismic Retrofitting

9-1 Background

9-2 The Act for Promotion of Seismic Retrofitting of Buildings

(Enforced on Dec. 25, 1995) (Revised and enforced on January 26, 2006)

9-3 Recent Amendment of the Act for Promotion of Seismic Retrofitting of Buildings (Revised on May 29, 2013)

9-4 Subsidy to Promote Seismic Assessment and Seismic Retrofitting

9-5 Seismic Retrofitting Techniques

9-1 Background

(1) Basic Seismic Code in Japan (1981)

Current seismic regulations in Japan are based on the seismic code enforced in 1981. (They have been sophisticated even after 1981.)

Revised code is not applied to the existing buildings unless extension work, etc. is done for them. Therefore, some old buildings remain unsafe.

(2) Great Hanshin-Awaji Earthquake (1995)

It hit Kobe city and surrounding regions and 104,906 buildings collapsed, and 6,148 buildings were severely damaged, causing 6,433 deaths. It is estimated that 90 % of the deaths were due to falling buildings or furniture.



Great Hanshin-Awaji Earthquake (1995)



(3) Enforcement of the New Law (1995)

Most of the collapsed buildings were those which were constructed before 1981. Therefore, seismic retrofitting became an urgent issue in Japan. Then, the Law for Promotion of Seismic Retrofitting of Buildings was established and enforced in the same year (1995).

Damage to buildings from the viewpoint of the construction year - the Great Hanshin-Awaji Earthquake (1995) -

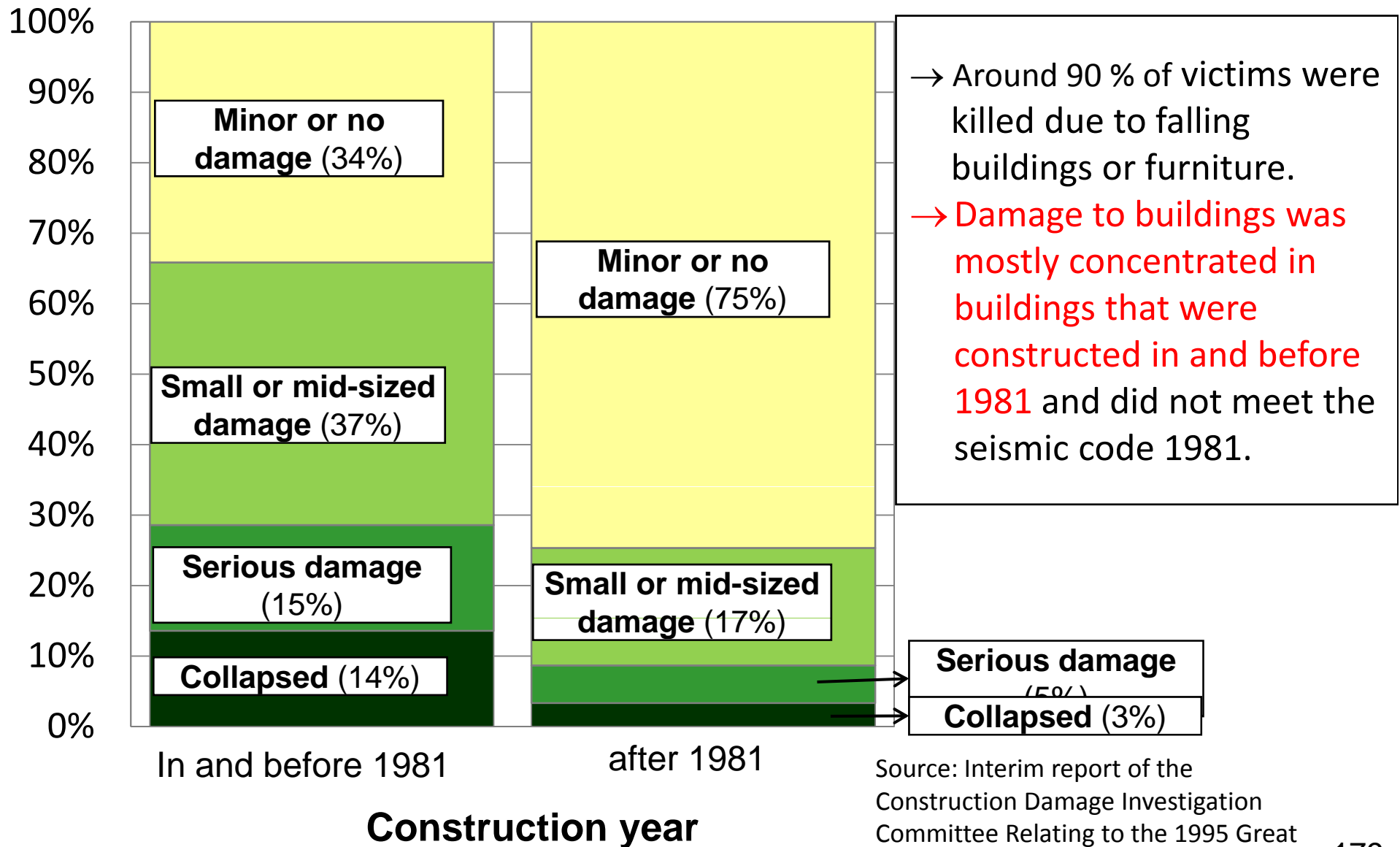

Source: Interim report of the Construction Damage Investigation Committee Relating to the 1995 Great Hanshin-Awaji Earthquake

9-2 The Act for Promotion of Seismic Retrofitting of Buildings (Enforced on Dec. 25, 1995) (Revised and enforced on January 26, 2006)

National Government's policies (based on the Act)

As for promoting seismic assessment and seismic retrofitting,

- Basic policies and **numerical targets** (to raise proportion of earthquake-resistant buildings to 90% by 2015)
- **Calculation methods for seismic assessment of buildings**
- Others

Local Governments' Promotion plans (based on the Act)

As for promoting seismic assessment and seismic retrofitting,

- Action plan and **numerical targets (including numerical targets for public buildings)**
- **Designation of emergency roads**
- Others



Guidance and advice by local governments

Objective buildings: (1) Buildings used by many people, such as schools, hospitals, theaters, department stores, offices, and rental housing, (2) Tall buildings along the designated emergency roads, and (3) Others

Obligation: Building owners are obliged **to make sincere effort at seismic assessment and seismic retrofitting** if necessary.

Guidance and advice: Local governments may give guidance and

Instruction and announcement by local governments

Objective buildings: (1) Large buildings used by many unspecified people, such as hospitals, theaters, department stores, elementary schools, and junior high schools, and (2) Others

Instruction and announcement: Local governments may give instructions and make public the buildings if necessary.



Order by local governments (based on the Building Standard Law)

Local governments may order building owners to retrofit their buildings based on the Building Standard Law **if the building has a risk of collapse.**



Penalties in cases where the building owners do not follow the order.

9-3 Recent Amendment of the Act for Promotion of Seismic Retrofitting of Buildings (Revised on May 29, 2013)

(1) Background

(a) Earthquake-resistant buildings

("Earthquake-resistant" represents "meeting to seismic code of 1981".)

It is needed to promote seismic retrofitting in order to achieve the target of the proportion of earthquake-resistant buildings.

Proportion of earthquake-resistant buildings

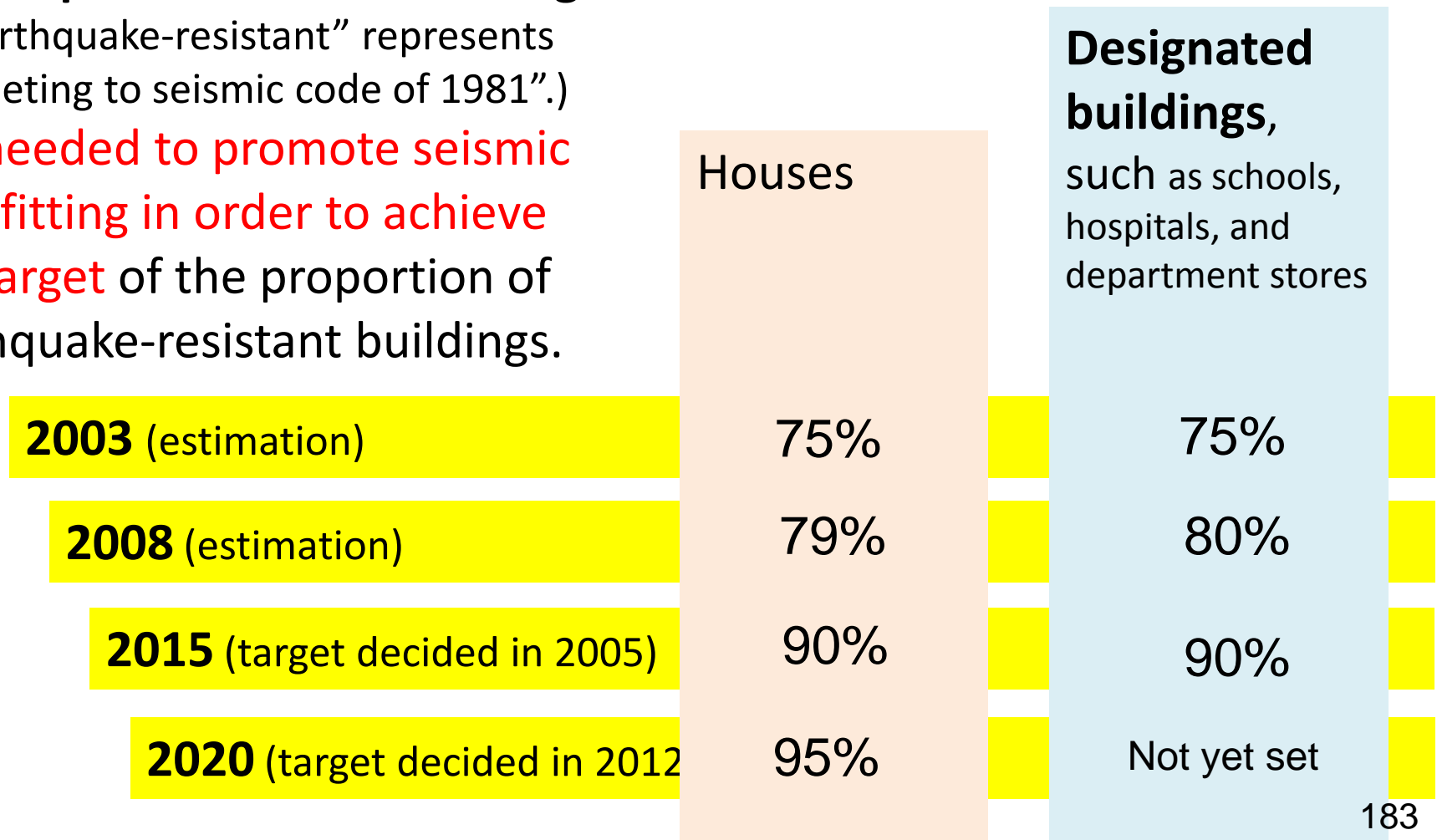

(b) Next Great Earthquake

In case where:

- **the Great Earthquake at Nankai trough** (offshore South-West Japan)

or

- **the Great Earthquake under Tokyo Metropolitan Area**

happens at the maximum range, it is estimated that the number of casualties and amount of damages will exceed those of the Great East Japan Earthquake in 2011.

the Great Earthquake at Nankai trough (offshore South-West Japan) at the maximum range

It is estimated that it will damage 940,000 to 2,400,000 buildings and cause 30,000 to 320,000 deaths. (Estimation in 2012)

(2) Points of Recent Amendment of the Act for Promotion of Seismic Retrofitting of Buildings

- (a) To place seismic assessment under an obligation, and
- (b) To make public the assessment results

Objective buildings of seismic assessment	Deadline of seismic assessment
(A) Large buildings used by many unspecified people, such as hospitals, department stores, and hotels (B) Large buildings used by underprivileged people for evacuation, such as elementary schools, junior-high schools, and home for the aged	Until the end of 2015
(C) Tall buildings along the designated emergency roads (D) Buildings used for a disaster prevention center	Until the date determined by the local government

The Act was revised on May 29, 2013.

9-4 Subsidy to Promote Seismic Assessment and Seismic Retrofitting

Subsidy ratio for the objective buildings of seismic assessment will be increased as shown in the table below, while subsidy for the other buildings is also available.

Objective buildings of seismic assessment	Subsidy for seismic assessment	Subsidy for seismic retrofitting
(A) Large buildings used by many unspecified people, such as hospitals, department stores, and hotels	10/10 <1/3>	2/3 <11.5%>
(B) Large buildings used by underprivileged people for evacuation, such as elementary schools, junior-high schools, and home for the aged		
(C) Tall buildings along the designated emergency roads (D) Buildings used for a disaster prevention center		4/5 <->

<Remark>

- 1. Ratio in the table** indicates subsidy ratio in case where National Government and the local government jointly give subsidy. They pay half each.
- 2. Ratio in the angle bracket** indicates subsidy ratio in case where National Government only gives subsidy, and the local government does not give subsidy.

9-5 Seismic Retrofitting Techniques

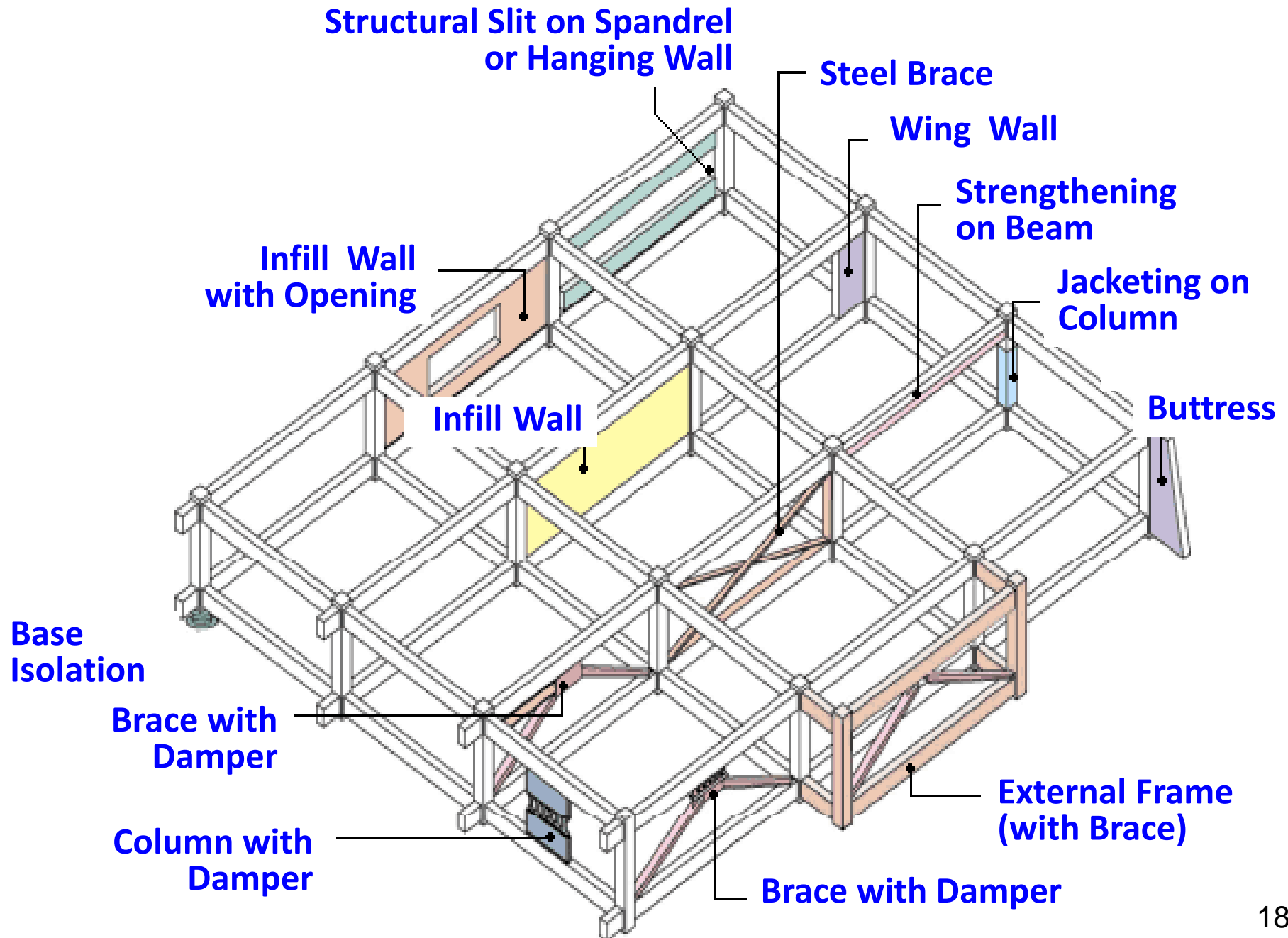

Extension of Shear Walls

Extension of Infill RC Wall



Extension of Infill Steel Brace

Jacketing of Columns

Steel

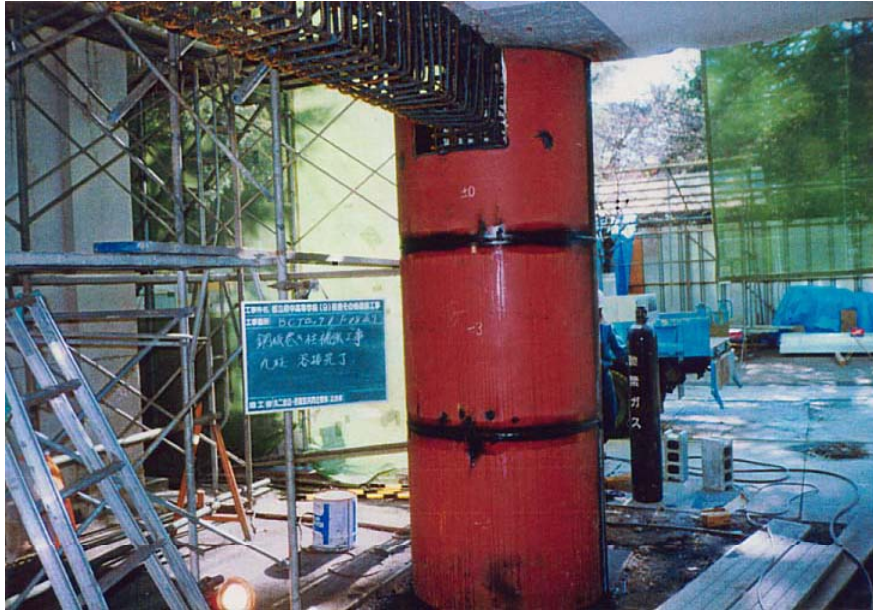

RC



FRP (Fiber Reinforced Plastic)

Structural Slit

Structural slit makes clear height of column and increase its ductility.

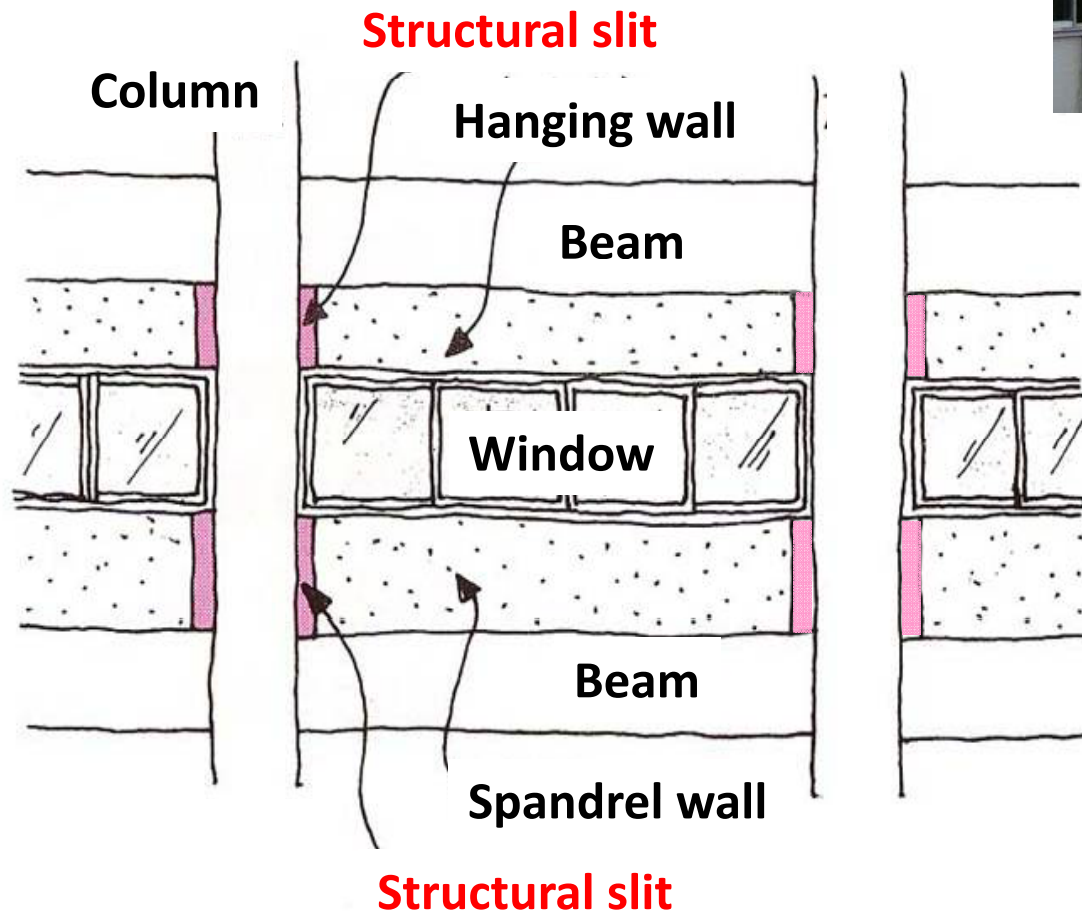

Shear Failure on Short Column (2004 Niigata-ken Chuetsu EG)

Examples of Seismic Retrofitting



Office building



School



Bank

Seismic Retrofitting by Seismic Base Isolation System

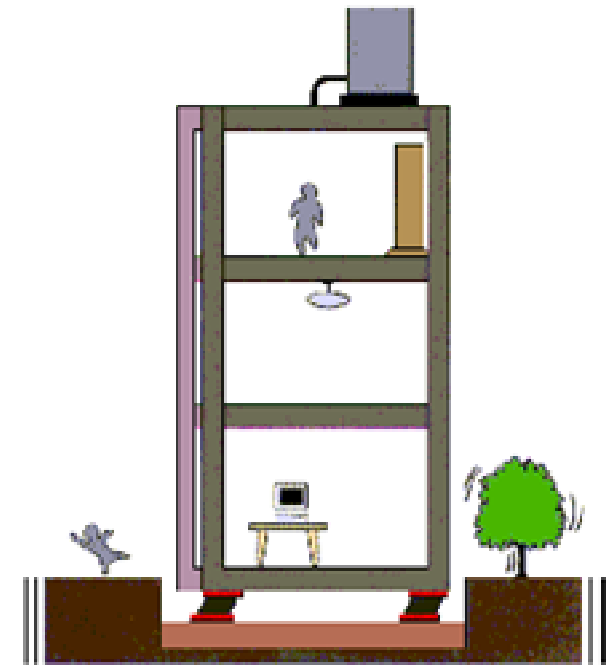

Base Isolation
Device

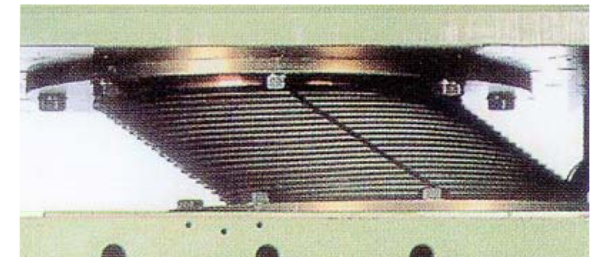

Annexes

Annex 1 Energy Saving Law

Annex 2 Housing Performance Indication System

Annex 3 Restrictions for interior finishing materials

Annex 4 Major wooden construction methods used for detached houses in Japan

Annex 5 Inspection items for single and two-story houses with post-and-beam wooden structures

Annex 1 Energy Saving Law

The Energy Saving Law has some provisions relating to the building regulations as below.

(1) Energy-efficiency Standard

Both of the Minister of Economy, Trade and Industry and the Minister of Land, Infrastructure, Transport and Tourism release guidelines on the design and construction of buildings for both non-residential buildings and houses. (Examples are shown in later.)

(2) Obligation of building owners to make certain efforts

Building owners must make efforts to contribute to the rationalization of energy use in buildings. *Competent Administrative Agencies*^{*1} provide building owners, who undertake the construction or renovation of specified buildings, with guidance and advice on the design, construction, and maintenance of buildings.

*1: The *Competent Administrative Agency* is a term defined in the Energy Saving Law. Most of them are *Designated Administrative Agencies* defined in the BSL.

(3) Mandatory notification

Owners of buildings (including residential buildings) with a total floor area of 300 m² or more, who undertake new construction or large-scale renovation projects are subject to mandatory notification to a *Competent Administrative Agency*, with regard to energy conservation measures.

<In case where a total floor area of a notified building is 2,000 m² or more>

If the notification includes extremely inadequate matters in comparison with the judgment criteria issued by the Ministers, the *Competent Administrative Agency* issues a directive. If the owner does not follow the directive, the *Competent Administrative Agency* may publish the fact or issue an order. If the owner does not follow the order, the owner will be fined.

For building owners who have notified the *Competent Administrative Agency*, they must file regular reports on the state of maintenance:

If the report includes extremely inadequate matters in comparison with the judgment criteria, the *Competent Administrative Agency* issues recommendations.

(4) Mandatory Standard for Energy Efficiency

It is planned to introduce a new regulation making it mandatory for newly built large-scale buildings to comply with energy efficiency standards. The target will be expanded, and It is planned to apply it to all newly built buildings and housing by 2020.

Energy-efficiency Standard for Non-residential Buildings

- The energy-efficiency standard for non-residential buildings consists of PAL for thermal insulation of building envelope and CEC for energy efficiency of building facilities.

PAL: Perimeter Annual Load, **CEC:** Coefficient of Energy Consumption

- CEC sets the standards for each of building facilities, i.e. CEC/AC (air conditioning), CEC/V (ventilation), CEC/L (lighting), CEC/HW (hot water supply), and CEC/E (elevator).
- The standards of PAL and CEC differ according to the purpose of buildings, such as, office, hotel, hospital, store, restaurant, school, community center, and factory.

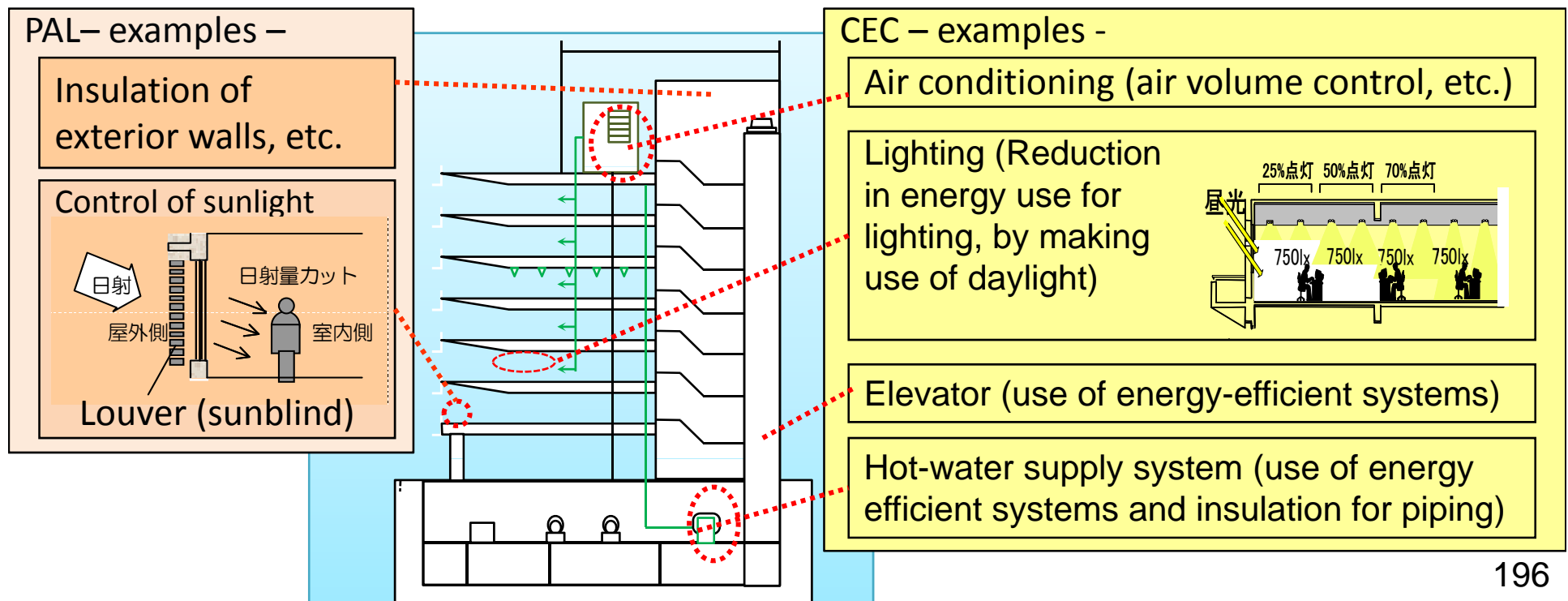

Energy-efficiency Standard for Houses

Dividing Japan into six regions, the standard values related to thermal insulation, air tightness, sun shading, etc. are provided for each region.

Example (1) of Energy-efficiency Standard for Houses

(specific standard, wooden house, Region IV including Tokyo)

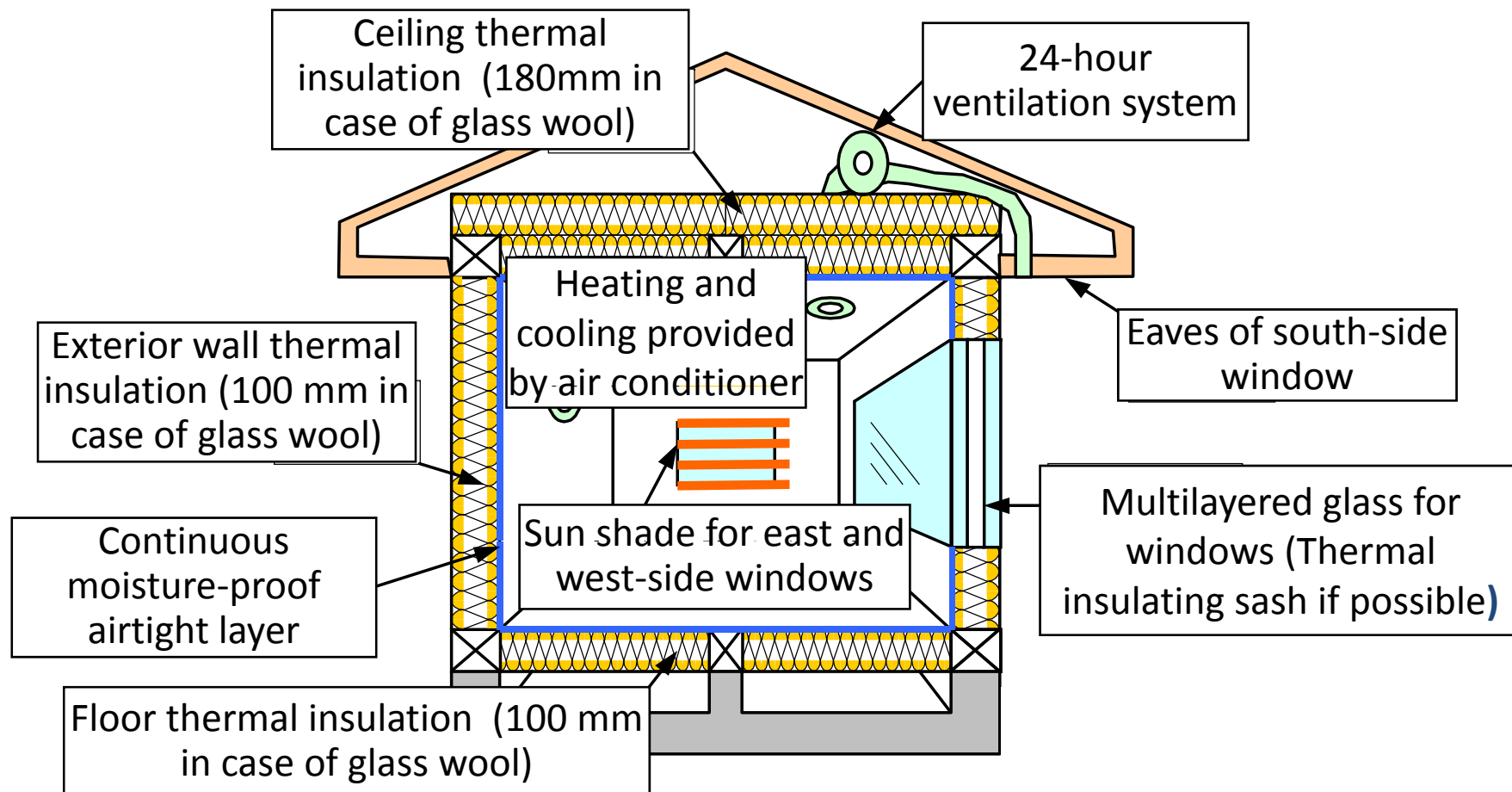

Example (2) of Energy-efficiency Standard for Houses

(Performance-based standard)

Heat loss coefficient (Q) should be less than the standard value provided for each region.

(1) Heat loss coefficient: Q value

Heat escaping to the outside from inside of the house when the temperature difference between the inside and outside is 1 ° C.

$$Q = \frac{Q_R + Q_W + Q_F + Q_V}{\text{Total floor area}}$$

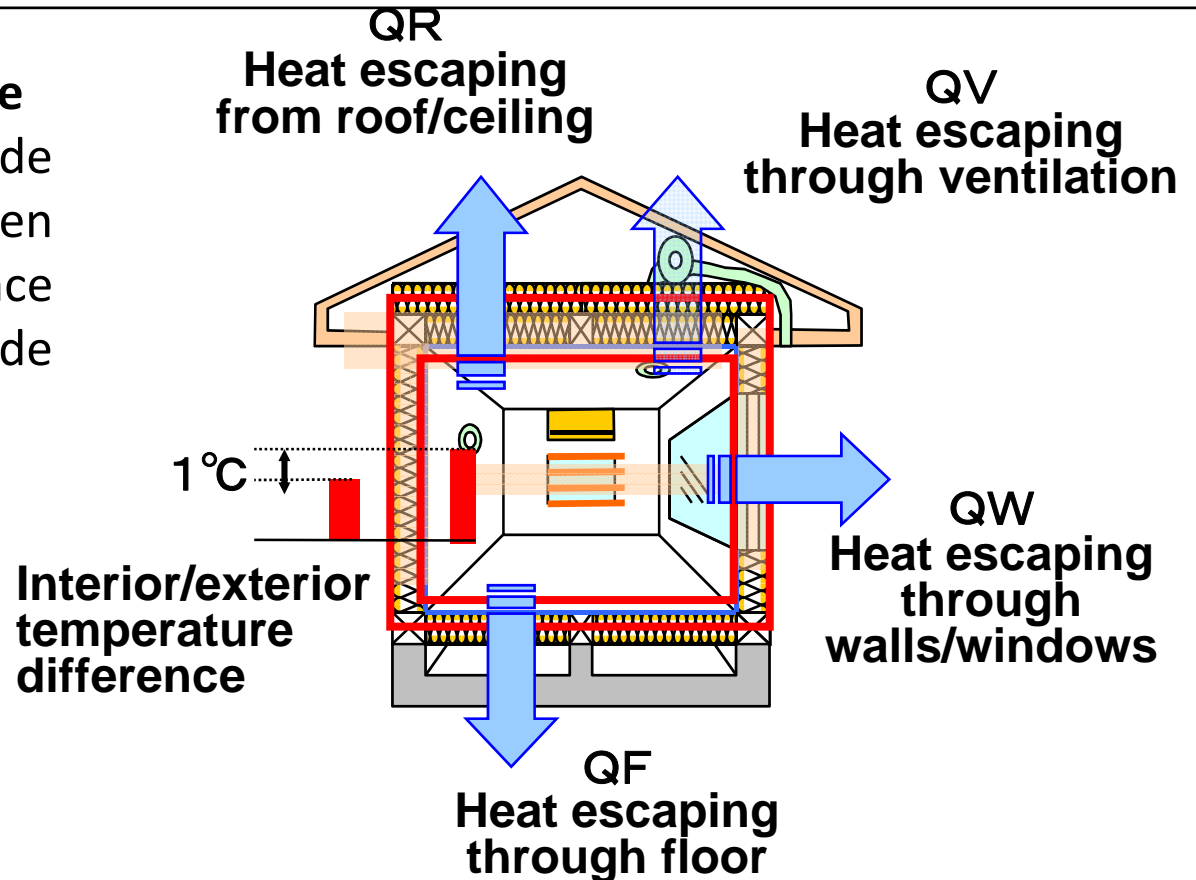

(2) Standard value for heat loss coefficient (Q)

	Region I	Region II	Region III	Region IV	Region V	Region VI
W / (m ² · K)	1.6	1.9	2.4	2.7	2.7	3.7

Background

- (1) Difficulty for consumers to compare the quality levels of one house to another
- (2) Difficulty for suppliers to prove that the quality of their houses is better than that of other houses

Purpose

Assurance of housing quality

Legislation

Based on the Housing Quality Assurance Act (HQAA) enforced in 2000.

Abbreviation

The BSL	The Building Standard Law
MLIT	The Ministry of Land, Infrastructure, Transport and Tourism
The Minister	The Minister of Land, Infrastructure, Transport and Tourism

Key points in comparison with The Building Standard Law

1. It applies only to the housing.

The BSL applies to all buildings.

2. It is a voluntary system.

Whether to use this system or not is up to housing buyers and suppliers, unlike with the Building Standard Law (BSL), which applies to all buildings. (In FY2008, 19% of newly-built housing were evaluated under this system.)

3. It covers 10 fields and 32 items.

The fields and items are different from those of BSL.

4. Evaluating services are conducted by independent bodies.

The system of independent bodies is similar to that of BSL. Type Approval System similar to that of BSL is also provided.

Japan Housing Performance Indication Standard covers 10 fields and 32 items.

- (1) In contrast to the Building Standard Law (the BSL), which stipulates minimum standards for building lots, structure and facilities, the "Housing Performance Indication System" (HPIS) covers performance levels exceeding the minimum standards of the BSL. (e.g., structural stability, which can withstand an earthquake of 1.25 times the impact stipulated in the BSL, is classified as to Level 2. And that of 1.5 times is classified as to Level 3.).
- (2) HPES also covers performance aspects not stipulated in the BSL (e.g., thermal insulation performance).

10 fields of Indications of Housing Performance

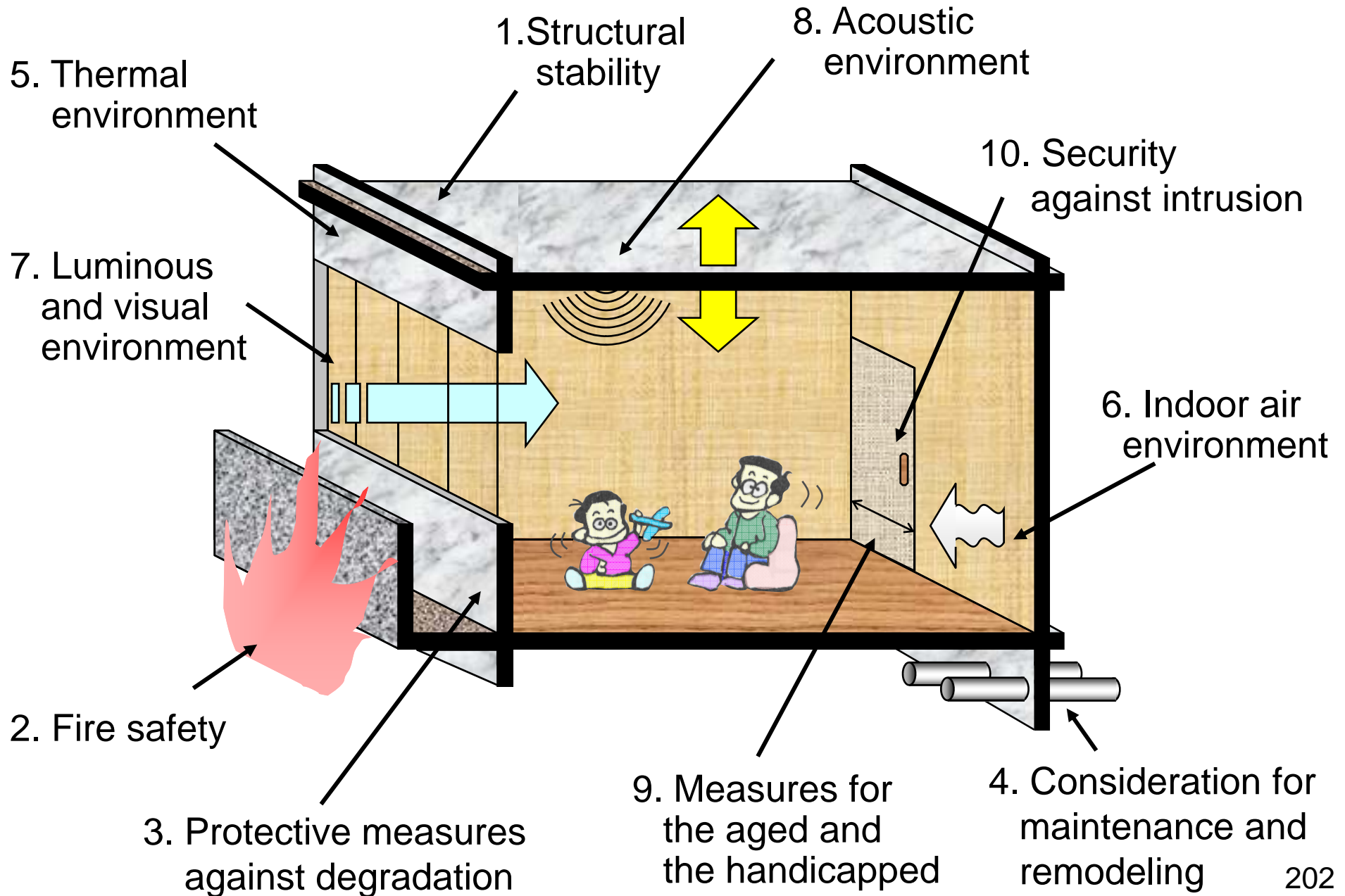

Indications of Housing Performance (Fields of No.1 to 5)

Fields of performance evaluation	Aspects of evaluation (main ones)
1. Structural stability	Structural stability against earthquakes, snow and wind
2. Fire safety	Fire detection and alarm devices
	Escape facilities (common hallways, staircases and escape equipment)
	Fire resistance of windows, external walls, boundary walls and floors
3. Protective measures against degradation	Measures against decay for wooden structures
	Depth of concrete covering for reinforcing bars for reinforced concrete structures
	Galvanizing or paint coating systems for steel frame structures
4. Consideration for maintenance and remodeling	Ease of Maintenance (inspection, cleaning and repair)
5. Thermal environment	Thermal insulation performance of external walls, windows and roofs

Indications of Housing Performance (Fields of No.6 to 10)

Fields of performance evaluation	Aspects of evaluation (main ones)
6. Indoor air environment	Reduction in formaldehyde diffusion from interior materials
	Ventilation systems
	Indoor measurement of concentration of chemical substances
7. Luminas and Visual Environment (Size of windows)	Ratio of window-area to floor-area
8. Acoustic environment	Sound-insulation performance of floors, walls and windows
9. Measures for the aged and the handicapped	Difference in floor levels,
	Width of corridors and doors
	Total area of bedrooms, bathrooms and lavatories
	Handrail equipment
10.Security against intrusion	Security performance of openings

Evaluation services are conducted by independent bodies.

- (1) In accordance with the Housing Quality Assurance Act, the "Registered Housing Performance-Evaluation Bodies " (REB), which are registered by the Minister (total 110 as of August 2008), are allowed to conduct housing performance evaluation services.
- (2) Building constructors, housing manufacturers and builders are able to use the service. The charges are set by each REB. depending on the number of dwellings, type of housing, etc. They range from around ¥50,000 to 100,000 per dwelling for apartments/condominiums when they have 50 dwelling units.

The evaluation services are carried out through examination of drawings and specifications in the **design stage** and four or more inspections in the **construction stage**. In the ten fields, indoor measurement of concentration of chemical substances and evaluation of the acoustic environment are carried out when the client requests it.

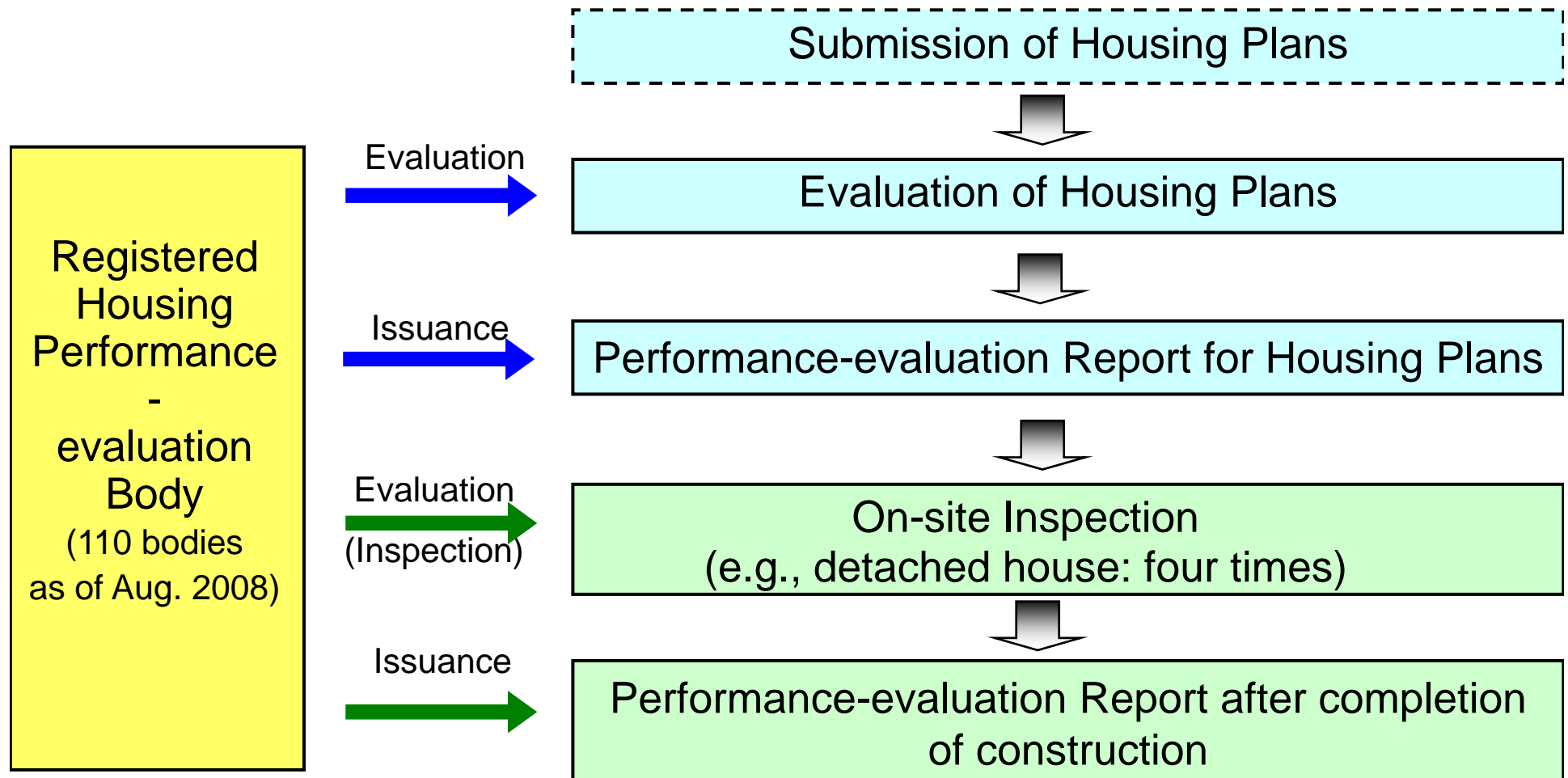

Annex 3 Restrictions for interior finishing materials

Restrictions for Interior Finishing Materials (1/6)

Usage of the buildings or parts of buildings, and cases where restrictions are applied			Parts where finishing materials must resist fire, and grade of materials required	
			Rooms	Corridors, stairs and other passageways
1	<ul style="list-style-type: none"> - Theaters - Movie theaters - Entertainment halls - Grandstands - Public halls - Assembly halls 	<p>(1) A <i>fire-resistive building</i>, of which seating space (*1) is 400 m² or more in total.</p> <p>(2) A building excluding <i>fire-resistive buildings</i>, of which seating space (*1) is 100 m² or more in total</p>	Internal parts of the wall (excluding the part up to 1.2 m from the floor) and ceiling in habitable rooms (*1) must be finished by FR (Q-NC is required for the 3rd or higher floors).	Internal parts of the walls and ceiling in corridors, stairs and other passageways that connect the rooms to the ground must be finished by Q-NC.
2	<ul style="list-style-type: none"> - Hospitals - Clinics (limited to those having patient accommodation facilities) - Hotels/inns, - Boarding houses - Apartment houses - Dormitories - <i>Welfare facilities(*2)</i> 	<p>(1) A <i>fire-resistive building</i>, of which floor area (*1) on the 3rd or higher floors is 300 m² or more in total</p> <p>(2) A <i>quasi fire-resistive building</i>, of which floor area (*1) on the 2nd floor is 300 m² or more in total (In the case of hospitals, this is only applied to a building which has a patient accommodation facility on the 2nd floor.)</p> <p>(3) A building excluding both <i>fire-resistive building</i> and <i>quasi fire-resistive building</i>, of which floor area (*1) is 200 m² or more in total</p> <p>Excluding parts partitioned into fire compartments of 100 m² (200 m² for apartment houses) or less</p>		

Restrictions for Interior Finishing Materials (2/6)

Usage of the buildings or parts of buildings, and cases where restrictions are applied			Parts where finishing materials must resist fire, and grade of materials required	
			Rooms	Corridors, stairs and other passageways
3	<ul style="list-style-type: none"> - Department stores - Markets - Exhibition halls - Cabarets - Cafes - Night clubs - Bars - Dance halls - Amusement halls - Public bathhouses - <i>Machiai</i> - Restaurants - Dining facilities - Stores engaged in commodity sales (excluding those with a floor area of 10 m² or less) 	<p>(1) A <i>fire-resistive building</i>, of which floor area (*1) on the 3rd or higher floors is 1,000 m² or more in total</p> <p>(2) A <i>quasi fire-resistive building</i>, of which floor area (*1) on the 2nd floor is 500 m² or more in total (In case of hospitals, only applied to a building which has a patient accommodation facility on the 2nd floor.)</p> <p>(3) A building excluding both <i>fire-resistive building</i> and <i>quasi fire-resistive building</i>, of which floor area (*1) is 200 m² or more in total</p>	Internal parts of the wall (excluding the part up to 1.2 m from the floor) and ceiling in habitable rooms (*1) must be finished by FR (Q-NC is required for the 3rd or higher floors).	Internal parts of the walls and ceiling in corridors, stairs and other passageways that connect the rooms to the ground must be finished by Q-NC.

Restrictions for Interior Finishing Materials (3/6)

Usage of the buildings or parts of buildings, and cases where restrictions are applied		Parts where finishing materials must resist fire, and grade of materials required	
		Rooms	Corridors, stairs and other passageways
4	<ul style="list-style-type: none"> - Buildings of three stories or more and with more than 500 m² of total floor area - Two story buildings with more than 1,000 m² of total floor area - Single story buildings with more than 3,000 m² of total floor area <p>The followings are excluded:</p> <ul style="list-style-type: none"> - Schools, gymnasias, or sports practice facilities; - Parts of buildings (*1) as specified in No. 2 above and at a height of not more than 31 m; - Parts of <i>fire-resistive buildings</i> or <i>quasi fire-resistive buildings</i> not for use as <i>special buildings</i> (see 5-3), which are at a height of not more than 31 m and are partitioned into fire compartment of 100 m² or less. 	Internal parts of the walls (excluding the parts up to 1.2 m from the floor) and ceiling in habitable rooms (*1) must be finished by FR	Internal parts of the walls and ceiling in corridors, stairs and other passageways that connect the rooms to the ground must be finished by Q-NC.

Restrictions for Interior Finishing Materials (4/6)

Usage of the buildings or parts of buildings, and cases where restrictions are applied		Parts where finishing materials must resist fire, and grade of materials required	
		Rooms	Corridors, stairs and other passageways
5	- Facilities for the use as mentioned in 1, 2, 3 above, under basement levels	Internal parts of the walls and ceiling in habitable rooms (*1) must be finished by Q-NC.	Internal parts of the wall and ceiling in corridors, stairs and other passageways that connect the rooms to the building exit must be finished by Q-NC.
6	- Automobile garages - Automobile repair shops		
7	- Habitable rooms without windows (Habitable rooms having a floor area exceeding 50 m ² and a total area of openable parts of openings such as windows (limited to those located in the ceiling or at a position 80 cm or less below the ceiling) less than 1/50 of the floor area of the habitable room concerned. Excluding rooms whose ceiling height exceeds 6 m)		
8	- Habitable rooms, the amount of which openings such as windows for natural lighting is less than the ratio specified in Article 19 paragraph 1 of the <i>Order</i> .		

Restrictions for Interior Finishing Materials (5/6)

Usage of the buildings or parts of buildings, and cases where restrictions are applied		Parts where finishing materials must resist fire, and grade of materials required		
		Rooms	Corridors, stairs and other passageways	
9	<ul style="list-style-type: none"> - Rooms having equipment that uses a flame, such as kitchens, bathrooms, boiler rooms, etc. <p>The followings are excluded:</p> <ul style="list-style-type: none"> - Rooms on the highest floor of houses that have two or more stories; - Rooms in buildings whose principal building parts are of <i>fire-resistive construction</i>. 	Internal parts of the walls and ceiling in rooms (*1) must be finished by Q-NC.	No requirements	
10	11th or higher floors	Within fire compartment of 100 m ² or less	No requirements (*3)	No requirements
		Within fire compartment of 200 m ² or less (Openings must be protected by <i>specified fire-preventive assemblies</i>)	Parts of the walls (excluding the part up to 1.2 m from the floor) and ceiling in rooms must be finished by Q-NC (including backing).	No requirements
		Within fire separation of 500 m ² or less (Openings must be protected by <i>specified fire-preventive assemblies</i>)	Parts of the walls (excluding the part up to 1.2 m from the floor) and ceiling in rooms must be finished by NC (including backing).	No requirements

Restrictions for Interior Finishing Materials (6/6)

Usage of the buildings or parts of buildings, and cases where restrictions are applied			Parts where finishing materials must resist fire, and grade of materials required	
			Rooms	Corridors, stairs and other passageways
11	Underground shopping malls	Within fire compartment of 100 m ² or less	No requirements (*4)	Parts of the wall and ceiling in underground passages must be finished by NC (including backing).
		Within fire compartment of 200 m ² or less (Openings must be protected by <i>specified fire-preventive assemblies</i>)	Parts of the walls (excluding the part up to 1.2 m from the floor) and ceiling in rooms must be finished by Q-NC (including backing)	
		Within fire compartment of 500 m ² or less (Openings must be protected by <i>specified fire-preventive assemblies</i>)	Parts of the walls (excluding the part up to 1.2 m from the floor) and ceiling in rooms must be finished by NC (including backing)	

Notes :

*1 Exclusively for use as stated in the left column

*2 *Welfare facilities* includes:

- children's welfare facilities;
- maternity clinics;
- rehabilitation facilities for physically disabled persons (excluding prosthetic appliances manufacturing facilities and information centers for visual/hearing impairment);
- social rehabilitation facilities for mentally disordered persons;
- protective institutions (excluding medical protective institutions);
- protective facilities for women;
- facilities for people with intellectual disability;
- welfare facilities for the elderly;
- fee-charging homes for the elderly; and
- maternal and child health facilities.

In No. 2, parts of a *1-hour quasi fire-resistive building* provided for use as a boarding house, apartment house, or dormitory, are treated as a *fire-resistive building*.

*3 In No. 10, parts of buildings partitioned into fire compartments of 100 m² or less are not subject to restrictions on materials used. However, such parts are subject to the provisions of No.4, regarding the number of stories and the scale of the building.

*4 In No.11, parts of buildings partitioned into fire compartments of 100 m² or less are not subject to restrictions on materials used. However, such parts, when offered for use as specified in No. 1, 2 or 3, are subject to the provisions of No.5.

Remarks:

- 1) These restrictions are not applied to parts of buildings with both:
 - automatic fire extinguishing equipment (such as sprinklers); and
 - smoke-exhaust equipment.

Regarding the provisions in No. 10 and No. 11, the floor area limit of the fire compartment may be increased two-times for parts of buildings where automatic fire extinguishing equipment (sprinklers, etc.) are provided.

- 2) If a building space falls under two or more provisions of restrictions on internal finishes (above), the strictest provisions of the restrictions are applied.
- 3) Instead of using FR, plywood boards, particle boards and other wooden materials may be used if they meet the specified standard.

Annex 4 Major wooden construction methods used for detached houses in Japan

The traditional Japanese building method is the wooden structure. Even now, most newly-built detached houses are wooden structures.

Three major wooden construction methods used for detached houses in Japan are as below.

(a) Post-and-beam wooden construction method (Right figure):

This is the most popular wooden construction method in Japan.

(b) Light-frame construction (Wood-frame construction):

This construction method is popular in North America.

(c) Wooden prefabricated construction:

This method is for constructing houses by assembling panels on the construction site.

(1) Post-and-beam wooden construction

This is the most popular wooden construction method in Japan. Its roots go back to ancient times.

Wooden braces have been common for 100 years.

Structural stability has improved over the past 50 years, through;

- increase in number of shear walls,
- use of structural laminated wood,
- use of metal fittings at joints.

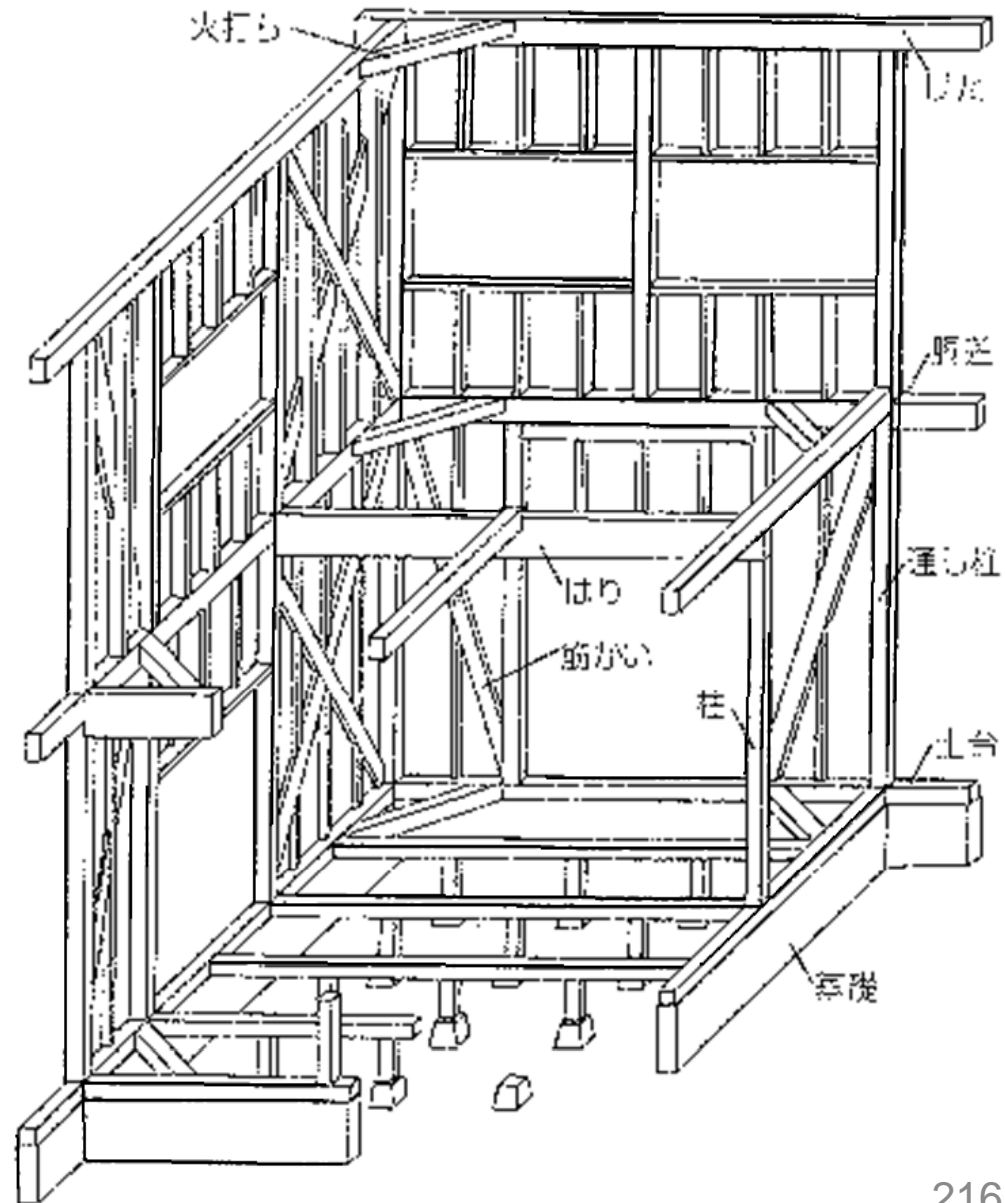

(2) Light-frame construction (Wood-frame construction)

This construction method is popular in North America. The Japanese building standard for this method was issued in 1974, then, this method became popular in Japan.

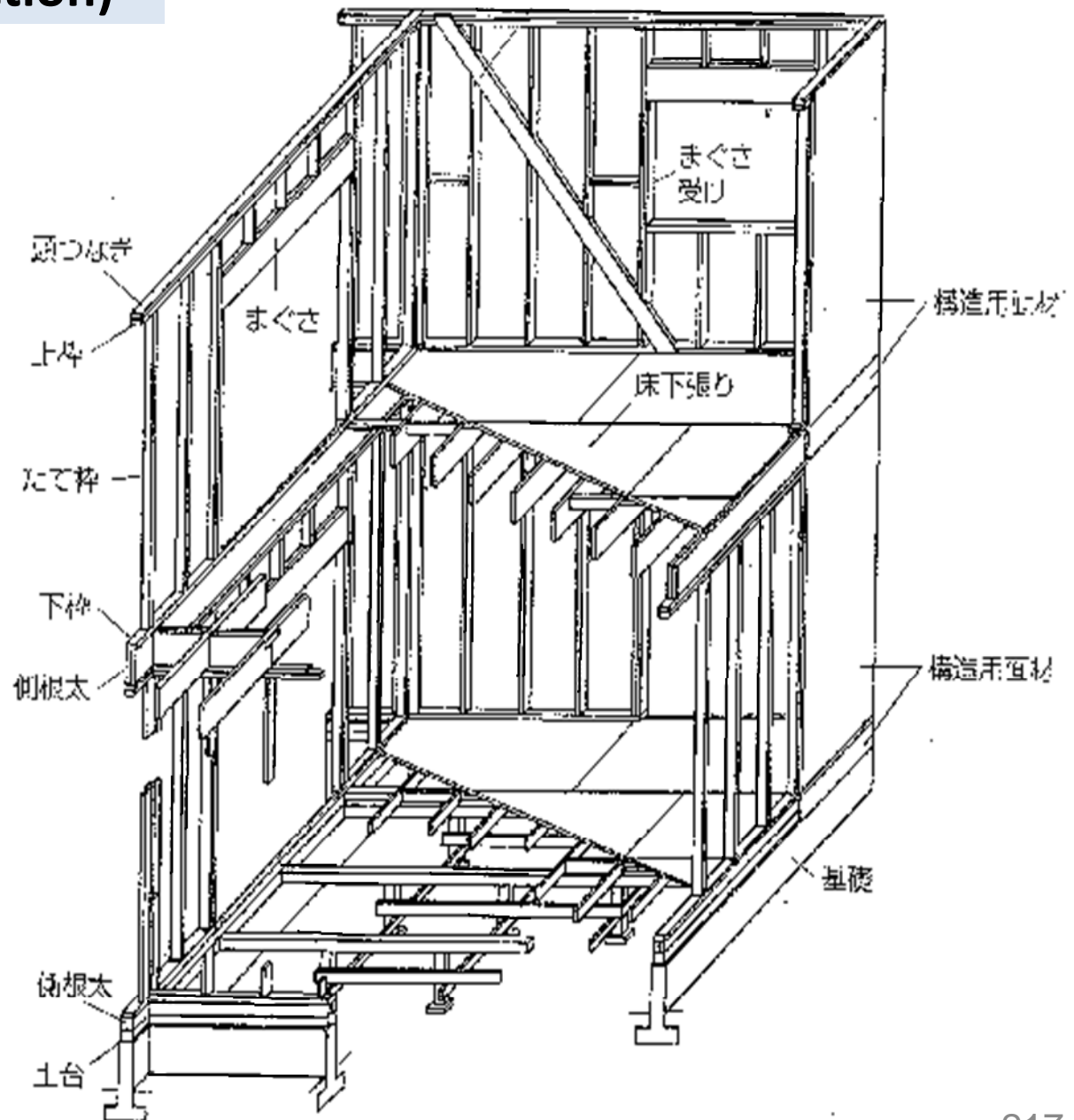

(3) Wooden prefabricated construction

This method is for constructing houses by assembling panels on the construction site, which are produced in factories by lining wooden frames with laminated wood, etc.

They appear similar to wood frame construction. Their structural members are joined by adhesive in many cases, while structural members of wood frame construction are joined by nails.

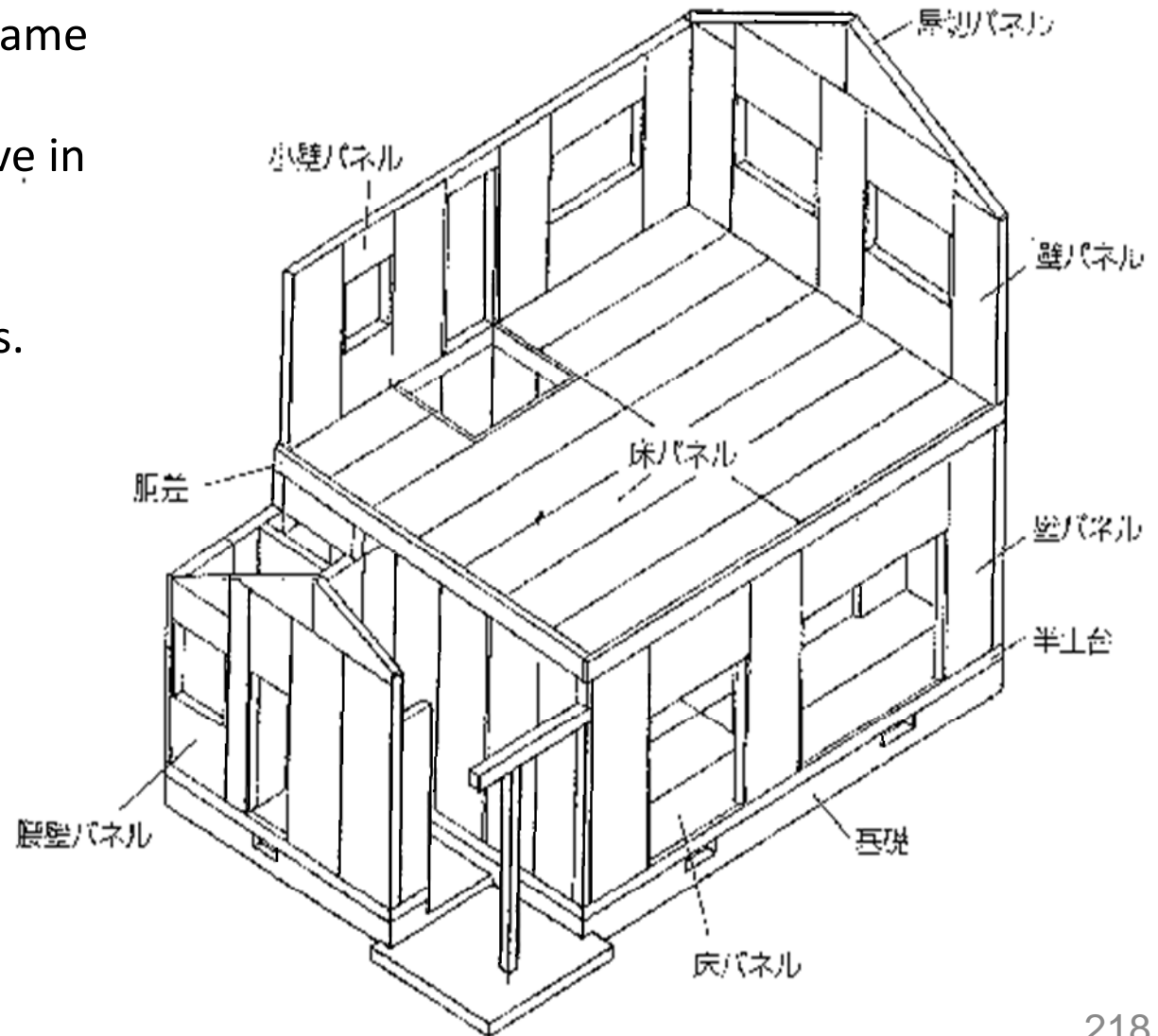

Annex 5 Inspection items for single and two-story wooden houses with Japanese conventional post-and-beam wooden structures

For single or two-story wooden houses with Japanese conventional post-and-beam structures, main on-site inspection items based on the Japanese Building Codes are as shown below.

Notes L: The Building Standard Law (The BSL)

O: The Enforcement Order based on the BSL

p: paragraph

(Example) L89p1 means Article 89 paragraph 1 of the Building Standard Law.

Exceptions Some requirements are not applied to:

- (1) Small structures, such as those with a floor area of not more than 10 m²;
- (2) Construction methods for which structural safety is confirmed by structural calculations; and
- (3) Construction methods that are approved by the Minister.

Main subjects

A Procedure	E Sill	I Roof truss
B Zoning Codes	F Column	J Roof
C Foundation	G Bearing wall	K Interior
D Wood	H Exterior wall	

A Procedure

A-1 Indicator board (L89 p1)

Building confirmation number (L6 p1)

Name of the person who conducts construction administration (L5-4 p2p3)

A-2 Drawings and specifications

These must be kept on the building site. (L89 p2)

B Zoning Codes

B-1 Front road (L42, 43, 44, etc.)

B-2 Height of buildings, etc. (L54, 55, 56, etc.)

B-3 BCR (building coverage ratio) and FAR (floor area ratio) (L52, L53)

B-4 Others

If the site is in a Fire-protection Zone, wooden structure buildings with a floor area of more than 100 m² are, in principle, not allowed to be constructed. (L61)

C Foundations

C-1 Foundation types (O38)

Possible type of foundation is as shown in the table according to the allowable soil bearing pressure for sustained loads of the building site. In a case where the structural safety of the foundation has been confirmed by structural calculations, other types of foundation may be used.

The allowable soil bearing pressure for sustained loads (P)	Possible types of foundation		
	Foundation piles	Mat foundations	Continuous foundations
$P < 20$ kilo Newton/m ²	○	×	×
$20 \leq P < 30$	○	○	×
$30 \leq P$	○	○	○

C-2 Ventilation under floors, damp-proofing (O22)

Either of the following, (1) or (2), below:

- (1) - The height from the ground to the floor surface of the lowest floor must be 45 cm or more; and,
 - ventilation openings (300 cm² or more) must be installed at a distance of no more than every 5 m along the exterior of the foundation. (Sill spacers for under-floor ventilation on the exterior of the foundation are also acceptable.)
- (2) The ground under the lowest floor must be covered with concrete or a suitable substitute.

Foundation structures of continuous foundations (unit: mm)

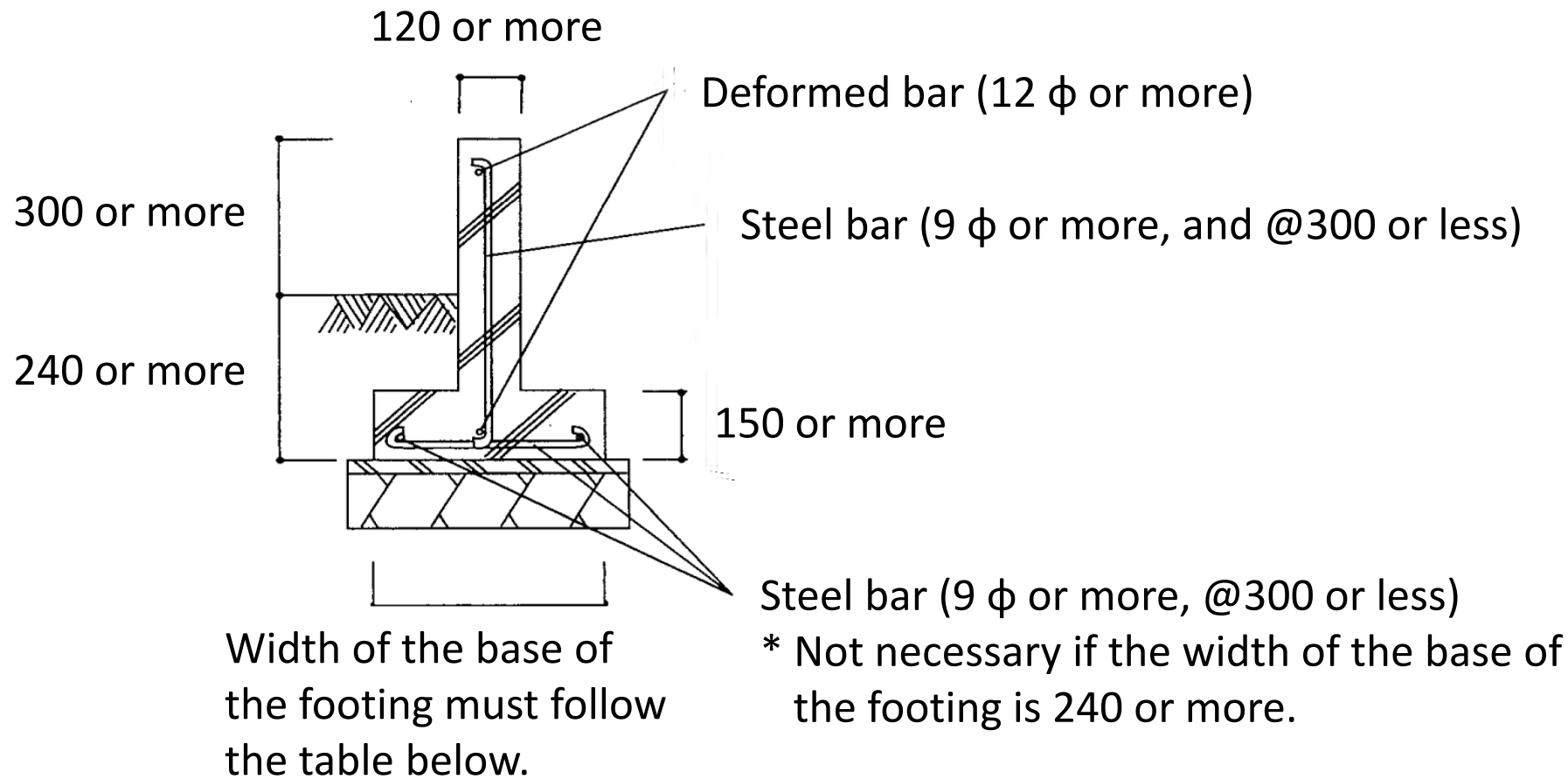

The allowable soil bearing pressure for sustained loads (P)	Width of base of footing	
	Single-story buildings	Two-story buildings
$30 \leq P < 50$ kilo Newton/m ²	300 or more	450 or more
$50 \leq P < 70$	240 or more	360 or more
$70 \leq P$	180 or more	240 or more

Foundation structures of mat foundations (unit: mm)

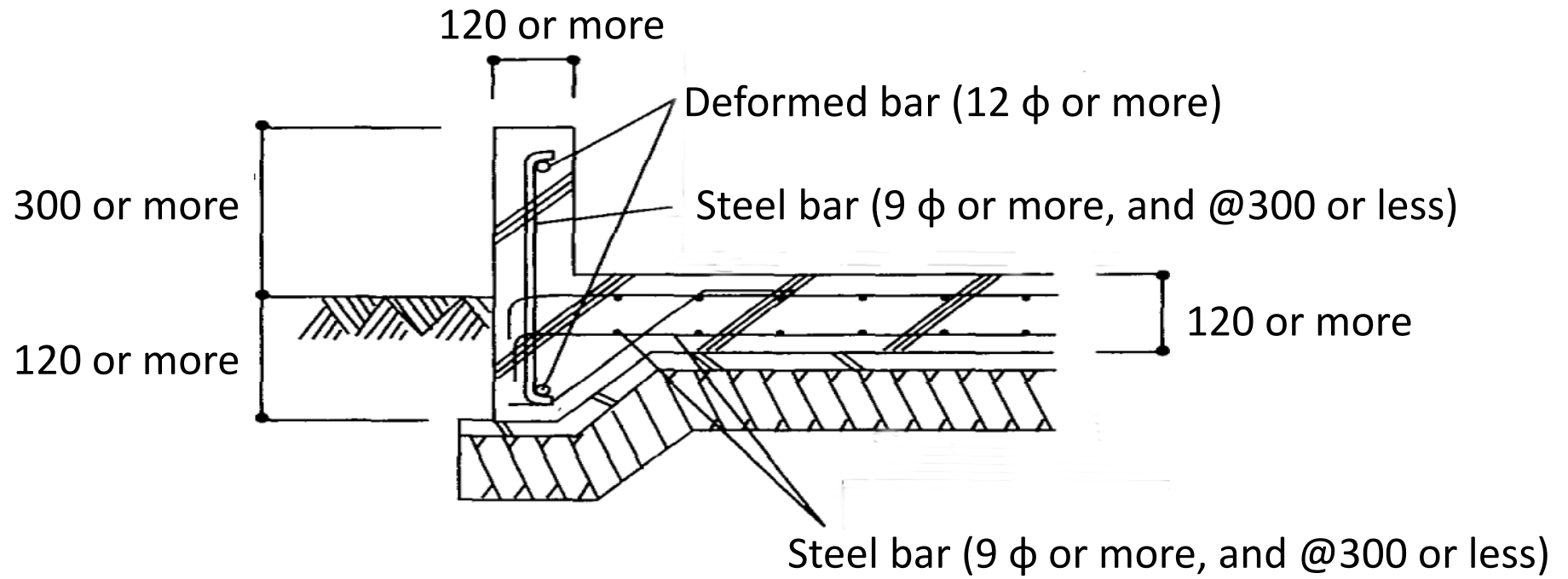

D Wood

D-1 Quality of wood (O41)

Timber to be used for elements that are necessary for structural resistance must be free from structural defects, such as knots.

D-2 Preservation of structural elements, prevention of termites (O49p2)

Structural elements up to 1m from ground level must be provided with effective preservation measures, as well as measures against termites and other insects, as necessary.

E Sill

E-1 Layout (O42p1)

The columns on the lowest floor must rest on the sills or be secured to the foundation.

E-2 Angle brace (O46p3)

Angle braces must be attached at angles of floor framing.

E-3 Anchor bolt (O42p2)

Sills must be secured to the foundation.

F Column

F-1 Width of columns

- (1) The ratio of the smallest width of the columns to the vertical distance between horizontal framing members must be not less than the ratio shown in the table below. (O43p1)

Story where the column is located	Top story	First story of two-story house
Roof materials		
Houses whose roofs are covered with light materials, such as metal, wood, or the like	1/33	1/30
Others	1/30	1/28

- (2) If 1/3 or more of the required width of columns is to be notched out, that part must be properly reinforced. (O43p4)

F-2 Continuous columns (O43p5)

Corner columns of buildings that have two stories, or other parts serving as these columns, must be continuous columns. unless they are properly reinforced at connections so as to provide strength equal or superior to that of continuous columns.

F-3 Effective slenderness ratio (O43p6)

The effective slenderness ratio of columns that constitute elements that are necessary for structural resistance (refers to the ratio of the buckling length to the minimum radius of gyration of the section) must be 150 or less.

G Bearing walls

G-1 Quantity of bearing walls (O46p4)

The quantity of bearing walls, such as frames with timber braces and frames with gypsum board, must exceed a certain value (which depends on the number of stories, floor area, etc.). (Reference 2)

G-2 Layout of bearing walls (O46p4)

Layout of bearing walls must be balanced so that the structure does not twist in case of earthquakes.

G-3 Joints/Connections of Structural Elements (O47)

Joints/Connections of structural elements must be connected by using bolts, steel plates, etc., as specified by the Minister.

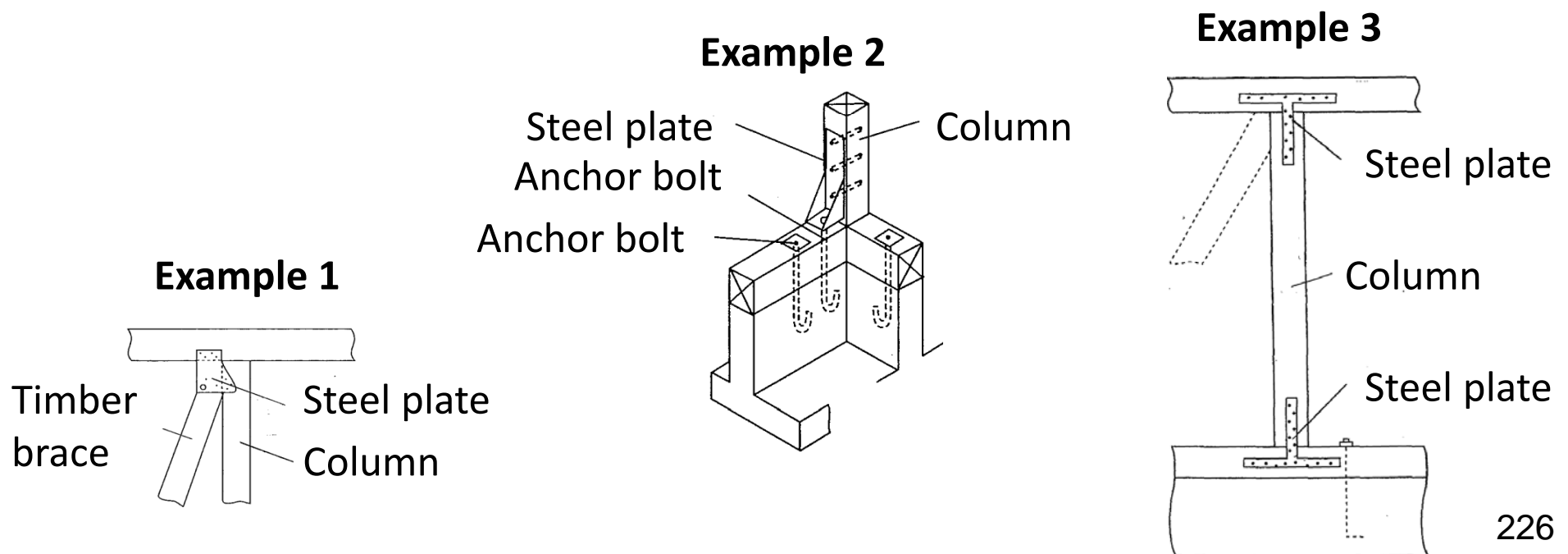

G-4 Notching of braces (O45p4)

In principle, notching must not be made on braces. However, if it is unavoidable, such as when braces cross, notches may be made as long as necessary reinforcement measures are taken.

G-5 Notching of horizontal framing members (O44)

Notching, which may affect structural strength, must not be made in the lower side in the vicinity of the middle portions of beams, girders or other horizontal framing members.

H Exterior walls

H-1 Fire resistance of exterior walls (L22, L64)

Exterior walls located in *parts liable to catch fire* (see Annex) must be covered by metal lath with mortar finish or similar material if the house is located in a:

- fire-protection zone;
- quasi fire-protection zone; or
- zone designated by the Designated Administrative Agencies, based on Article 22 of the BSL.

H-2 Openings in exterior walls (L64)

Openings located in *parts liable to catch fire* (see Annex) must be fitted with certain *fire-protective assemblies* if buildings are located in either *Fire Protection Zones* or *Quasi Fire Protection Zones*.

I Roof trusses

I-1 Angle braces (O46p3)

Angle braces must be attached at corners of tie-beam framing

I-2 Braces (O46p3)

Inter-truss braces must be attached at roof trusses

J Roof

J-1 Noncombustible material (L22, L63)

Roofs must be made of, or covered with, noncombustible material if the house is located in a:

- fire-protection zone; or
- quasi fire-protection zone; or
- zone designated by the Designated Administrative Agencies, based on the BSL.

J-2 Connecting (O39p1)

Roofing material, etc. must be secured so as not to detach due to wind, earthquakes, etc.

K Interior

K-1 Habitable Rooms

(a) **Natural light** (L28p1)

Habitable rooms of houses must have openings, such as windows, for natural light, and the ratio of the area effective for natural light to that of the floor area of such habitable rooms must be 1/7 or more.

<Exception> Rooms below under ground level

(b) **Mechanical ventilation** (L28-2p3, O20-8p1)

Houses must be equipped with mechanical ventilation equipment so that all habitable rooms are ventilated 0.5 times or more per hour.

(c) **Height of ceiling** (O21)

The average ceiling height of each habitable room must be 2.1 m or more.

(d) **Fire Alarm** (Fire Service Law)

Fire alarm equipped with smoke detectors must be installed in bedrooms, etc.

K-2 Kitchen

(a) Ventilation (L28p3)

A kitchen that has equipment that uses a flame must have ventilation equipment.

(b) Finishing materials (O128-4p4, O129p6)

In cases where a house has two stories, and has a kitchen that has equipment on the first floor that uses a flame, the interior surfaces of the walls and ceiling of the kitchen must be finished with quasi-noncombustible materials. (Noncombustible materials are included in quasi-noncombustible materials as a definition).

(c) Fire Alarms (By-law based on the Fire Service Law)

Fire alarms equipped with heat detectors must be installed in kitchens in areas where it is required by the by-law.

K-3 Stairs (O23p1, O25p1)

(a) Dimensions of risers and treads

See **figure** at bottom right.

(b) Handrails

Stairs must be equipped with handrails.

Exception: parts at a height of 1 m or less

(c) Width of stairs

Width of stairs must be 75 cm or more. The distance from the wall to the outer edge of handrail may be counted towards the width of stairs, up to 10 cm. (See **figure** at bottom left.)

Width of stairs

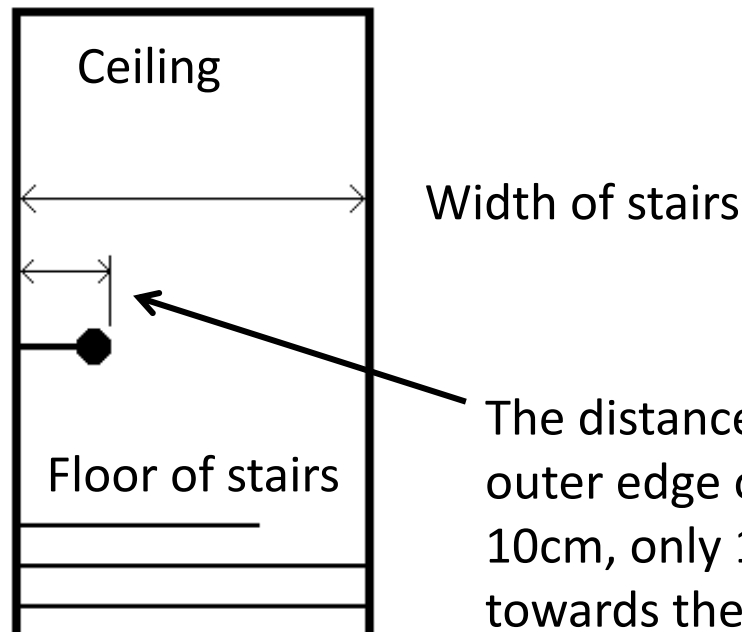

The distance from the wall to the outer edge of handrail. If it is over 10cm, only 10 cm may be counted towards the width of stairs.

Risers and treads in housing units

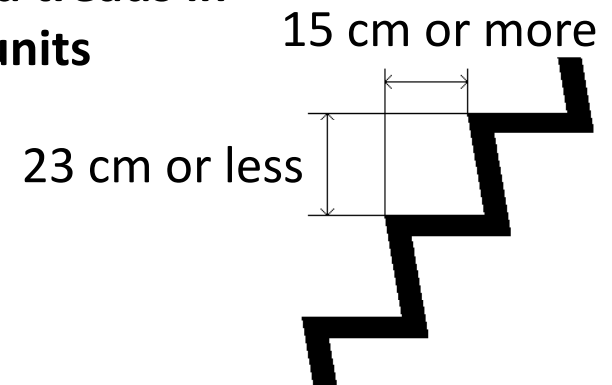

K-4 Toilets (O32)

Commodes must be connected to public sewerage or wastewater purifiers, which meet requirements specified by the Minister.

K-5 Chemical Substances

(a) **Asbestos** (L28-2, O20-4)

Building materials must not contain more than 0.1 % of asbestos, by weight.

(b) **Chlorpyrifos** (L28-2, O20-5, O20-6)

Building materials must not contain chlorpyrifos.

(c) **Formaldehyde** (L28-2, O20-7)

The use of building materials that emit formaldehyde is regulated.

Reference 1: Definition of *Parts Liable to Catch Fire* (L2p6)

Parts liable to catch fire are parts of a building within a distance of:

- 3 m for the first floor; or
- 5 m for the second, or higher floors,

from any of the following:

- the boundary line with the adjacent land lot;
- the center line of the road;
- the center line between exterior walls of two or more buildings on the same site. (For this purpose, two or more buildings with an aggregate total floor area not exceeding 500 m² are regarded as one building.)

However, any parts facing an open space or a body of water that is effective for fire safety, such as a park, public square, river, or facing walls of fire-resistive construction, or the like, are not considered *parts liable to catch fire*.

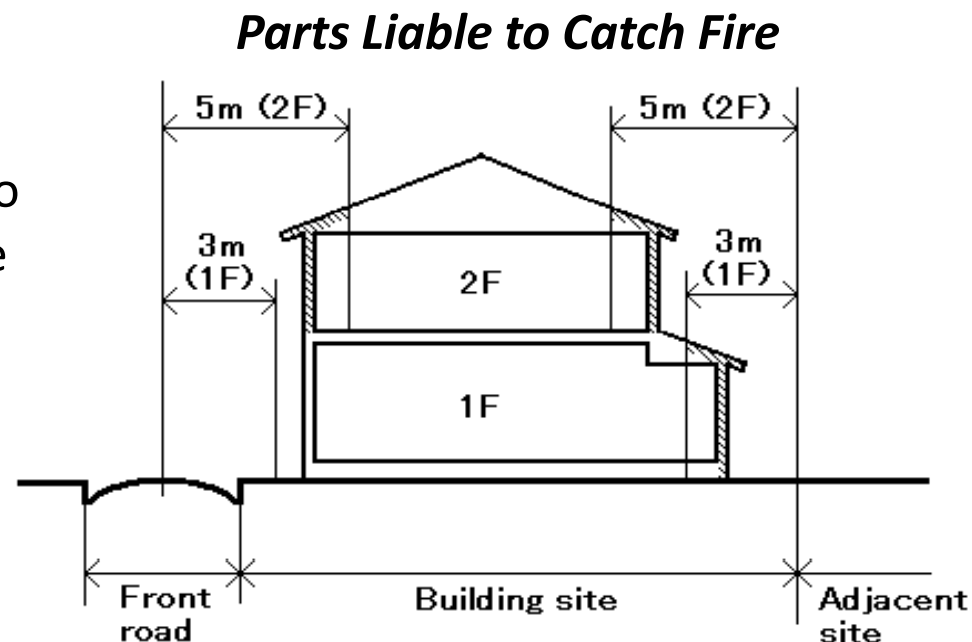

Reference 2: Confirmation method of structural resistance of frames for Japanese conventional post-and-beam structures (O46)

Objective buildings:

Wooden buildings with two or more stories or with a total floor area exceeding 50 m²

Requirements:

$$A \geq B \text{ and } A \geq C$$

in each direction of both the span and longitudinal directions on each floor

A: the sum of the length obtained by multiplying the length of each frame having either walls or braces in the same direction by one of the figures shown in the column of “Multiplier” of the Table 1 according to the classification of frames as shown in the column of “Type of frame” of the table

B: the value obtained by multiplying the floor area of the floor by one of the figures shown in Table 2 (in areas designated by the Designated Administrative Agency under Article 88 paragraph 2, the figures will be 1.5 times those in Table 2)

C: the value obtained by multiplying the plumb measure size (referred to as the “vertically projected area in the span or longitudinal direction”) of the floor (including higher floors if any) minus the plumb measure size of the portion of the floor up to a height of 1.35 m from the floor level, by one of the figures shown in Table 3.

Table 1

	Type of frame	Multiplier
(1)	Frames with earth-plaster walls or frames with walls with wooden lath or the like nailed to one side of columns and studs	0.5
(2)	Frames with walls with wooden lath or the like nailed to both sides of columns and studs	1
	Frames with a timber brace 1.5 cm or more in thickness and 9 cm or more in width or with a steel bar brace 9 mm or more in diameter	
(3)	Frames with a timber brace 3 cm or more in thickness and 9 cm or more in width	1.5
(4)	Frames with a timber brace 4.5 cm or more in thickness and 9 cm or more in width	2
(5)	Frames with a timber brace 9 cm or more square	3
(6)	Frames with "X" braces shown in any of (2) through (4)	Two times each value of (2) through (4)
(7)	Frames with "X" braces shown in (5)	5
(8)	Other frames approved by the Minister of Land, Infrastructure, Transport and Tourism or frames using a structural method specified by the Minister as having such strength as equal or superior to that of the frames shown in one of (1) through (7)	A value to be specified by the Minister within the range between 0.5 and 5
(9)	Frames with walls shown in item (1) or (2) and braces shown in one of (2) through (6)	The sum of the value of (1) or (2) and that of one of (2) through (6)

Table 2: Multiplier for the floor area of each floor (unit: cm/m²)

Buildings		Story	Single-story buildings	two-story buildings	
				First floor	Second floor
(1)	Buildings whose roofs are covered with light materials, such as metal sheets, stone plates, wooden boards		11	29	15
(2)	Buildings other than those in (1)		15	33	21

(Note) For this table, basement levels shall not be included in counting the number of stories.

Table 3: Multiplier for plumb measures size (unit: cm/m²)

Areas		Multiplier
(1)	Areas designated by the Designated Administrative Agency by regulations as strong wind areas, based on past data on wind	A value to be determined by the Designated Administrative Agency by regulations based on the wind conditions in the region concerned within a range exceeding 50 and not more than 75
(2)	Areas other than the above	50



Thank you